



**A M C R E S T**

## HDCVI DVR Quick Start Guide

# Table of Contents

Check Packaging .....	1
1. Front/Back Panel Diagrams & Descriptions .....	1
Front Panel.....	1
Rear Panel.....	3
2. Hardware Setup.....	4
Setting up the cable connections.....	4
Hard drive installation .....	11
3. Console Setup.....	13
Logging in.....	13
Startup Wizard walkthrough .....	14
4. Motion Detection & Recording Setup .....	20
Setting up recording schedules.....	20
Setting up motion detection and email alerts.....	25
5. Computer Access Setup.....	32
Amcrest IP Config Software method .....	33
Built-in interface method .....	37
Installing the Amcrest browser plugin .....	38
Setting up DVR Local Access (home or business) .....	39
Setting up DVR Remote Access (away from home) .....	40
Remote access not working? (troubleshooting steps) .....	45
Web Interface Walkthrough .....	47
6. Amcrest View App Setup .....	48
Enabling P2P on the DVR .....	48
App setup not working? (troubleshooting steps) .....	59
Amcrest View Pro interface overview .....	60
7. Amcrest View Web Portal Setup.....	61
Installing the AmcrestView.com browser plugin.....	61
User method.....	64
AmcrestView Web Interface Overview .....	74
8. References & Contact Information.....	76

## Welcome

Thank you for purchasing our DVR!  
This quick start guide will help you become familiar with our DVR in a very short time.  
Before installation and operation, please read the below safeguards and warnings carefully.

Many of the setup sections below have corresponding videos on YouTube  
To access the setup videos, please go to <http://amcrest.com/videos>



## Important Safeguards and Warnings

- All installations and operations here should conform to your local electrical safety codes.
- We assume no liability or responsibility for any of the fires or electrical shocks caused by improper handling or installation.
- We are not liable for any problems caused by unauthorized modifications or attempted repair.
- Improper battery use may result in fire, explosion, or personal injury.
- When replacing the battery, please make sure you are using the same model.

## Check Packaging

When you receive the DVR system in the packaging, unpack it, and check all sides of the DVR to see if there is any physical damage. The protective materials used for the packaging of the DVR can protect most accidental damage during transportation, but to ensure that your equipment is operating as expected, it is recommended to inspect the product before proceeding further.

On the DVR unit, check specifically that the label on the bottom of the DVR is not damaged. The serial number of the unit is often needed to provide support.

Please check that all required items for your DVR are present and accounted for. To check what is included with your purchase, go to <http://amcrest.com/ip-security-camera-systems.html/> and find the product you purchased, then scroll down and click the "What's Included" tab. If any item is missing, please contact us as soon as possible so we can send you the missing component(s)

# 1. Front/Back Panel Diagrams & Descriptions

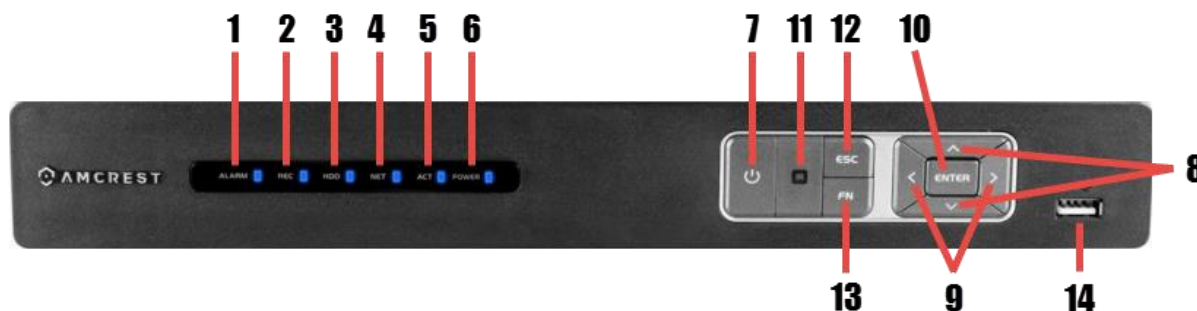

## Front Panel

**Note:** For detailed operating instructions, please refer to the User's Manual on the included CD or found on the product listing online: <https://amcrest.com/hdcvi-security-camera-systems.html>



Please refer to the following chart for information on the front panel buttons



#	Icon	Name	Function(s)
1	ALARM	Alarm status indicator light	When an alarm event occurs, this LED becomes blue to alert you.
2	REC	Recording status indicator light	When the DVR is recording footage to the hard drive, this LED will become blue to alert you.
3	HDD	HDD status indicator light	When an HDD error occurs or the HDD capacity is below the specified threshold, this LED becomes blue to alert you.
4	NET	Network status indicator light	When a network error occurs or there is no network connection, this LED becomes blue to alert you.
5	ACT	ENTER	Confirms the current operation.
6	POWER	Power status indicator light	When the DVR is powered on, this LED will remain blue.
7		Power button	Press and hold the power button for 3 seconds to boot up or shut down the DVR.
8		Up/Down	Activates current controls, modifies settings, and allows navigating up and down through options.
			Increases/Decreases numerals.
			Assists in functions such as PTZ menu.
9		Left/Right	Shifts current activated controls.
			When in playback, use these buttons to control the playback bar.
10	ENTER	Enter	Confirms the current operation.
			Goes to the default button.
			Goes to the menu.

11		IR receiver	This is used to receive the signal from the remote control.
12	ESC	Escape	Go to the previous menu or cancel the current operation.
			When in playback, push ESC to restore real-time monitoring.
13	Fn	Assist	In one-window monitoring, push this button to display additional functions such as PTZ control and image color.
			Backspace function: in numeric/text control, press Fn for 1.5 seconds to delete the character before the cursor.
			In motion detection setup, use the Fn button and directional keys to adjust the settings.
			In text mode, push Fn to switch between numeric and English characters (small/capitalized), etc.
			Activates other special functions.
14		USB 2.0 port	USB 2.0 port: connect a mouse, USB storage device, etc.

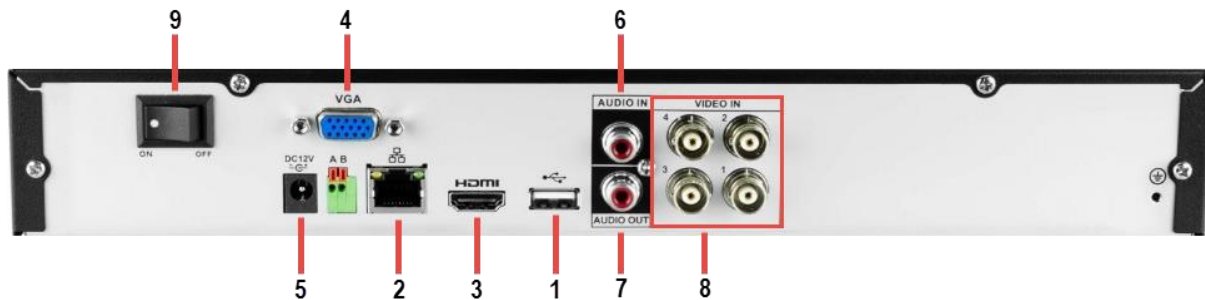
**Rear Panel**

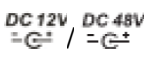

Please refer to the following chart for detailed information on the rear panel ports:

#	Port	Connection	Function
1		USB 2.0 port	USB 2.0 port: connect a mouse, USB storage device, etc.
2		Network port	10M/100M self-adaptive Ethernet port. Connects to the network.
3	HDMI	High Definition Multimedia Interface port	High definition audio and video signal output port. It transmits uncompressed high definition video and multiple-channel data to the HDMI port of the display device. HDMI version is 1.4.
4	VGA	Video Graphics Array output port	VGA video output port: outputs analog video signal. It can connect to a monitor or TV to view analog video.
5		Power input port	Power socket: <ul style="list-style-type: none"> <li>• NV1104/NV4108: Input DC 48V/1.25A/</li> </ul>
6	MIC IN	Audio input port	Bidirectional talk input port: this receives the analog audio signal output from the devices such as a microphone.
7	MIC OUT	Audio output port	Audio output port: used to output the analog audio signal to devices such as the sound box. <ul style="list-style-type: none"> <li>• Bidirectional talk output</li> <li>• Audio output on 1-window video monitor</li> <li>• Audio output on 1-window video playback</li> </ul>
8	Coax	Coaxial cable ports	Video port for standard coaxial cables to connect your cameras. Can also transmit audio and PTZ signals in higher-end models.
9	Power switch	N/A	Power button for manually turning DVR ON or OFF.

## 2. Hardware Setup

Before setting up the DVR, you will probably need the following items. The items are not included:

- A computer monitor or TV with either an HDMI or VGA input
- A power strip with room for 4 large power plugs

It is recommended to connect all components of the system as shown below *before* mounting any of the cameras. This is to ensure all components are working. If any components are not functioning, please contact Amcrest Support.

### Setting up the cable connections

The following instructions will show you how to set up the cables for the DVR, cameras, as well as a monitor or TV screen.

To set up the DVR's cable connections, there are 7 major steps:

1. Connect a monitor or TV screen to your DVR. The DVR is compatible with any monitor or screen that uses a VGA or HDMI connection. For purposes of this guide, we will use a VGA connection. Take a VGA cable, and connect one end to the VGA port on your monitor/screen and the other end to the VGA port on the back panel of your DVR.



2. Connect a USB mouse (included) to the front of the DVR.



3. Connect an Ethernet cable to your router.

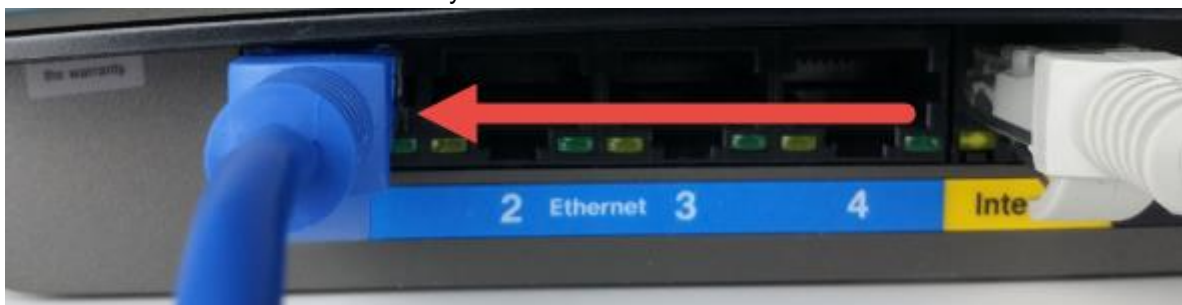

Then, connect the other end of the cable to the DVR.





4. Connect the camera video extension cable to the camera's video cable and connect the camera power extension cable to the camera's power cable. There should be a tag on the video cable to help you make sure the right end of the cable is at hand.



5. Connect the camera cable to any of the video input (coaxial) ports on the DVR.



6. Connect the camera power extension cable to one of the camera power cables, connect this power cable into the power brick, and then plug the cable into an electrical socket.

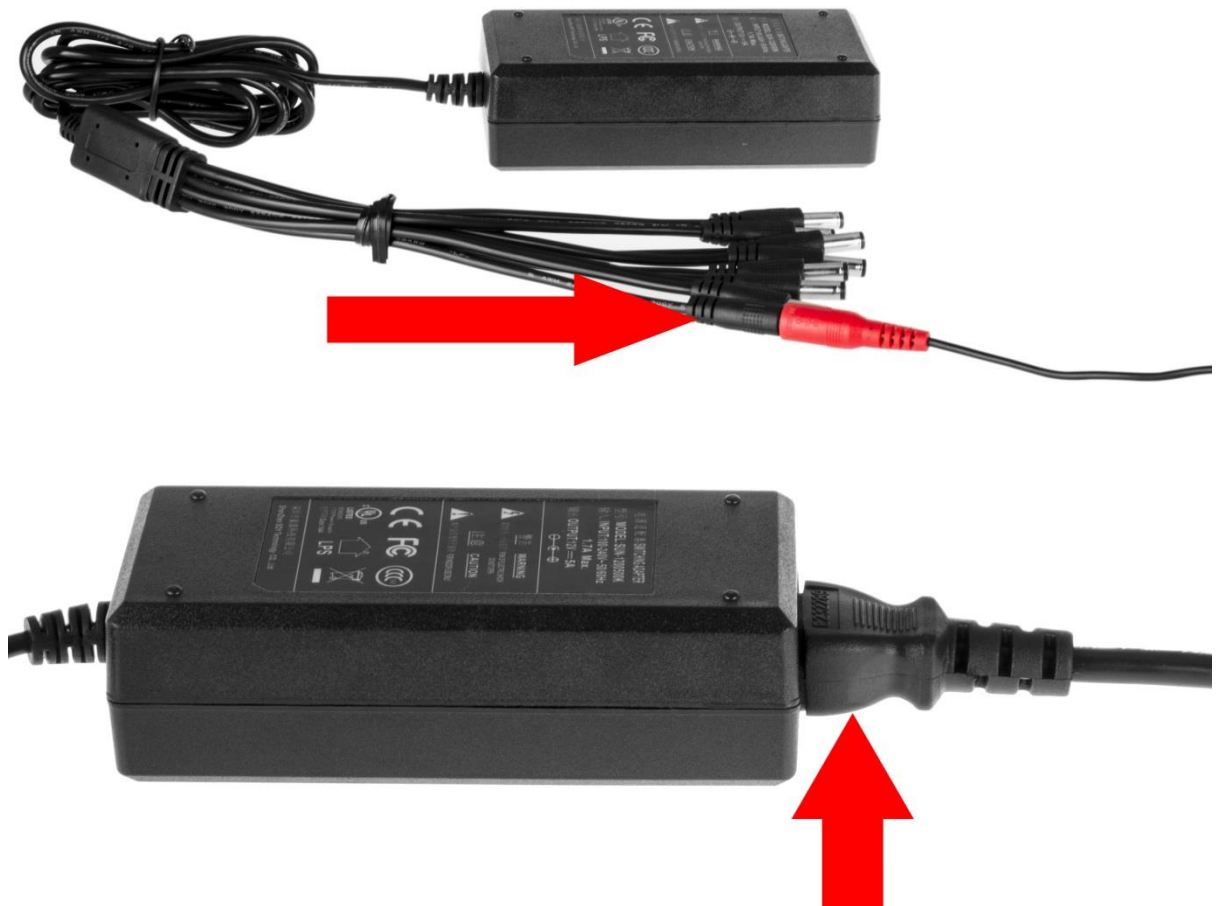

7. Connect the DVR power cable into the back of the DVR, and then plug in the DVR power adapter into an electrical socket.



8. Make sure that the power switch is in the ON position.

## - PLEASE READ BELOW-

**Note: Your DVR may not work properly if the following is not accounted for.**

Every single DVR comes preset to a video output resolution of **1280x1024**. What this means is that any time an HDMI cable is plugged into an HDTV, it may result with a blank screen even if the DVR is operational.

If this occurs, please follow the steps below.

### Procedure using a VGA cable:

1. Connect your DVR to a computer monitor or TV screen with a VGA cable (the HDMI cable should not be connected during this process).
2. Boot up your DVR. On the monitor or TV, please make sure the "input" is set to VGA.
3. When the interface loads, you will see the login screen appear. Enter your credentials. (To find your login credentials, please refer to part 3 of this guide: **Console Setup > Logging in.**)
4. On your DVR, open the Main Menu by left-clicking once on the live feed screen and, under the Settings row, click on the System icon.

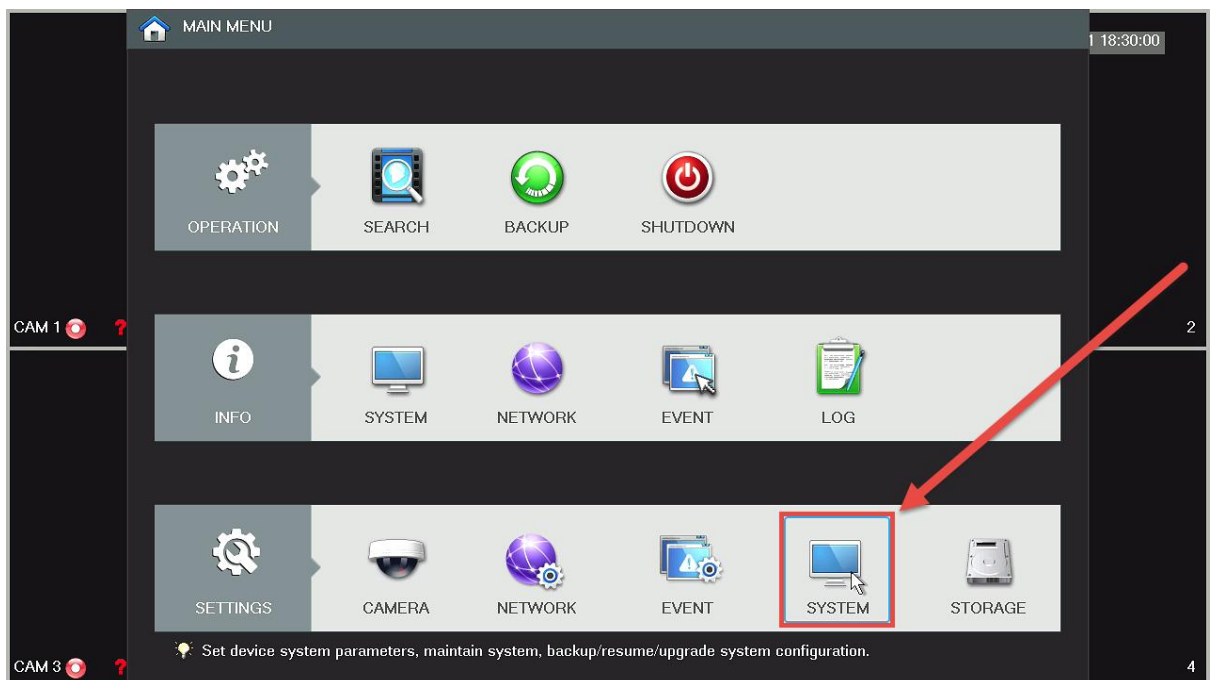

- Then, on the new window, click Display from the list on the left column of options. Change your resolution from **1280x1024** to **1920x1080** and click **Apply** down below. Your DVR will reset to effect the change.

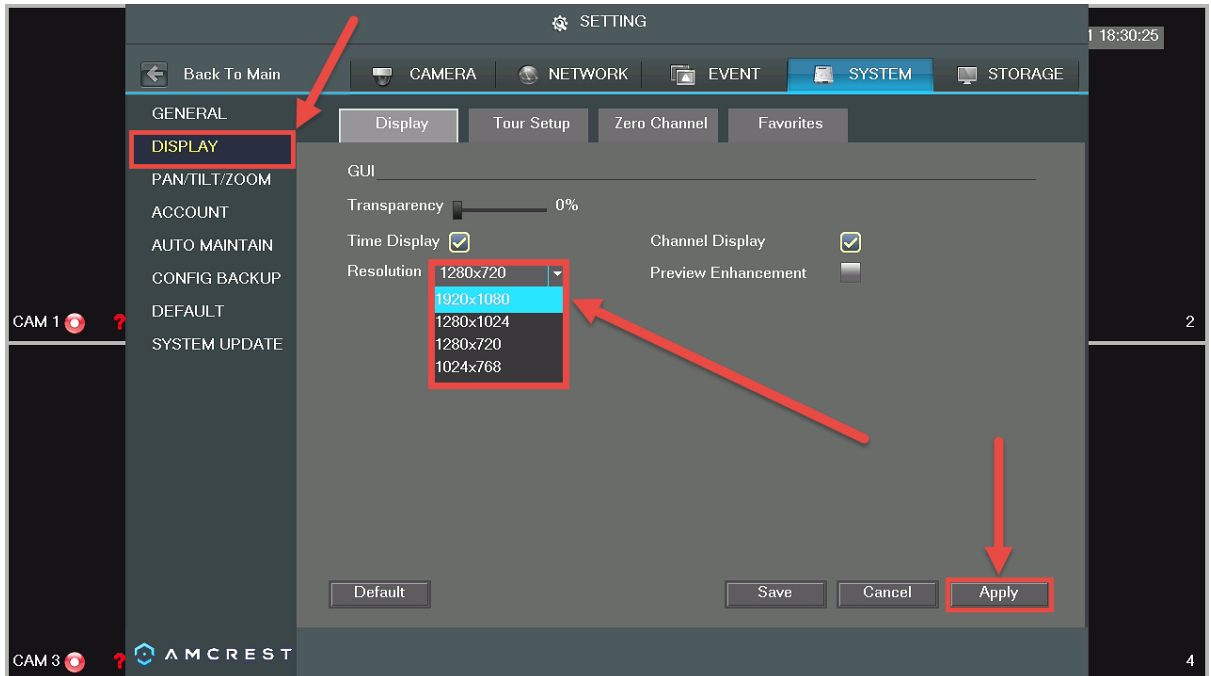

- Disconnect the VGA cable and connect your DVR to an HD monitor or TV using an HDMI cable. Don't forget to change the input to HDMI on a TV. Your interface will now appear and you can use your DVR freely.

## Hard drive installation

A hard drive allows you to configure and use the recording functionality of this DVR, including playing back previously recorded footage.

**Note: This section *only* applies to HDCVI DVRs purchased without a hard drive already pre-installed. Most 'kits' or 'bundles' will come with a pre-installed hard drive.**

The DVR has connections for only 1 hard drive inside the case and the hard drive must be no bigger than 4TB (Terabytes).

In order to install your hard drive, the following is needed:

- A medium sized (regular) Phillips-head screwdriver - *not included*
- A hard drive - *not included (unless you purchased a 'kit' that **does** have one included)*
- Four hard drive fastening screws - *included*

**Note: Before installing the hard drive, make sure the DVR is powered off with the power cable disconnected.**



1. Loosen the screws of the upper cover and side panel.

2. Attach four screws in the HDD (Turn just three times).

3. Place the HDD in accordance with the four holes in the bottom.



4. Turn the device upside down and then turn the screws in firmly.

5. Attach the HDD firmly.

6. Connect the HDD cable and power cable.



7. Put the cover in accordance with the clip and then place the upper cover back on.

8. Secure the screws in the rear panel and the side panel.

Once the hard drive is installed, boot your system and, for any cameras that are configured to be recording, you will see the following 'recording' icon appear in the bottom-left corner of the live view window for that camera:



### 3. Console Setup

#### Logging in

After turning the system on, the default video display shows multiple windows and a page will appear that asks you to change your password and set up security questions:

The screenshot shows the 'ADMINISTRATOR' login screen. It features the following fields and callouts:

- Username:** A dropdown menu with 'admin' selected. Callout: 'Enter default username: admin'.
- Old Password:** A password field with six dots. Callout: 'Enter new password, then confirm'.
- New Password:** A password field with six dots.
- Confirm Password:** A password field with six dots.
- Secure Question:** A section with two questions:
  - Question 1:** 'What's your favorite pet?' with a dropdown arrow. Callout: 'Enter security question #1'.
  - Answer:** A text field containing 'sparky'.
  - Question 2:** 'What's your first car model?' with a dropdown arrow. Callout: 'Enter security question #2'.
  - Answer:** A text field containing 'corolla'.
- Buttons:** 'OK' and 'Cancel' buttons at the bottom. A red arrow points to the 'OK' button.

First, you will need to enter the default “old” password.

**The default password to enter into the Old Password field is: admin**

Once you’ve entered “admin” (without quotes) into that field, proceed to enter a new password into the **New Password** field, then enter your new password one more time into the **Confirm Password** field to confirm it.

Please note that the system consists of two accounts (out of the box):

- **Username:** admin **Password:** admin (administrator, local and network)
- **Username:** default **Password:** default (hidden user)

Then, choose a question from the **Question 1** dropdown, and enter your answer. Do the same for **Question 2**.

**Note: Please write down the new username and password credentials you’ve just created as well as both the security questions and their answers.**

After you’re done here, click **OK**.



You will see a confirmation screen that your password has been successfully modified:



If you do not see this screen after clicking **OK**, please confirm that you've correctly filled out the required fields.

### Startup Wizard walkthrough

The first page of the Startup Wizard will appear:

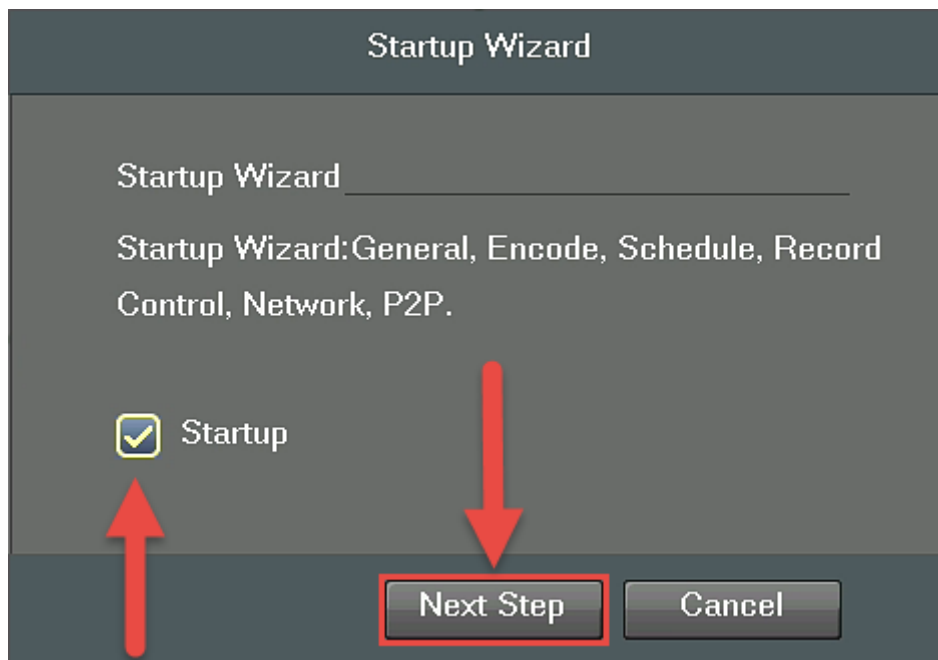

If you do not want to use the Startup Wizard, or you've already gone through it and don't want it to keep appearing, unmark the checkbox next to **Startup** and click **Cancel**.

**Note:** Every page from the Startup Wizard that follows can be accessed and modified at any time through the Main Menu.

To login to the system for the first time, click **Next Step** and the login screen will appear.

You will be asked to log in for the first time now. Enter your new credentials:

**Username:** admin

**Password:** (your new password)

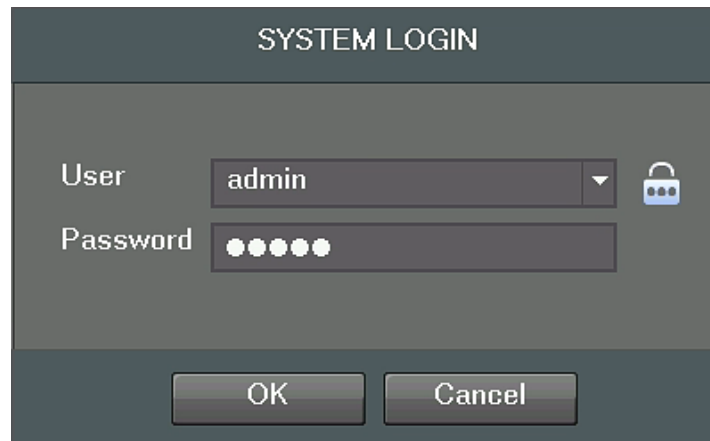

The image shows a 'SYSTEM LOGIN' dialog box. It has a dark grey background with white text. At the top, it says 'SYSTEM LOGIN'. Below that, there are two input fields: 'User' and 'Password'. The 'User' field contains the text 'admin' and has a dropdown arrow on the right. To the right of the 'User' field is a blue padlock icon. The 'Password' field contains six white dots. At the bottom of the dialog, there are two buttons: 'OK' and 'Cancel'.

**Note:** If three failed logins are attempted within a 30 minute time period, the system will set off an alarm. After five login failures, the account will be locked.

The next screen that comes up is the **GENERAL** settings screen. Make sure to click the tabs at the top for Date & Time, as well as Holiday to configure those settings as well. Once you are satisfied with the settings on this screen, click the **Next Step** button at the bottom of the screen.

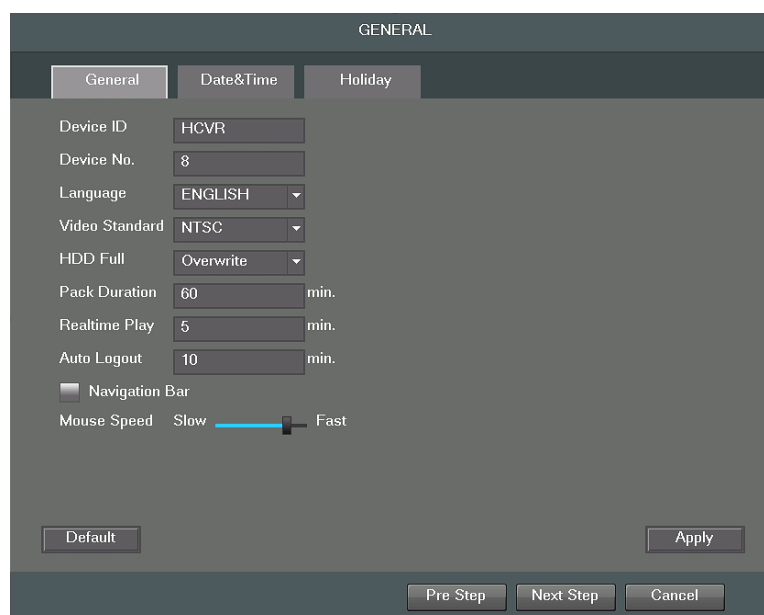

The image shows the 'GENERAL' settings screen. It has a dark grey background with white text. At the top, it says 'GENERAL'. Below that, there are three tabs: 'General', 'Date&Time', and 'Holiday'. The 'General' tab is selected. Below the tabs, there are several settings: 'Device ID' (HCVR), 'Device No.' (8), 'Language' (ENGLISH), 'Video Standard' (NTSC), 'HDD Full' (Overwrite), 'Pack Duration' (60 min.), 'Realtime Play' (5 min.), 'Auto Logout' (10 min.), 'Navigation Bar' (checkbox), and 'Mouse Speed' (Slow to Fast slider). At the bottom, there are three buttons: 'Default', 'Apply', and 'Next Step'.

The next screen that appears is the **ENCODE** settings screen. This is where you can adjust the video quality settings for your DVR/cameras, including the compression and frame rate. Make sure to check the **Snapshot** and **Overlay** tabs to see those settings too.

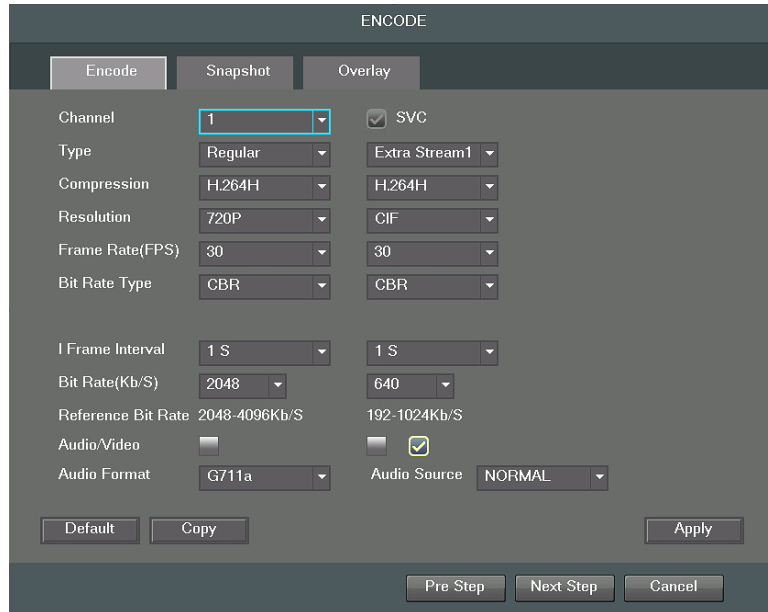

The next screen you see is the Schedule settings screen. Make sure to click the tabs at the top for Record and Snapshot to configure those settings as well. Your DVR is configured, by default, to record everything on all channels 24/7 (this will only actually happen provided you have a hard drive installed). You can also use this screen to set up motion detection and alarm schedules.

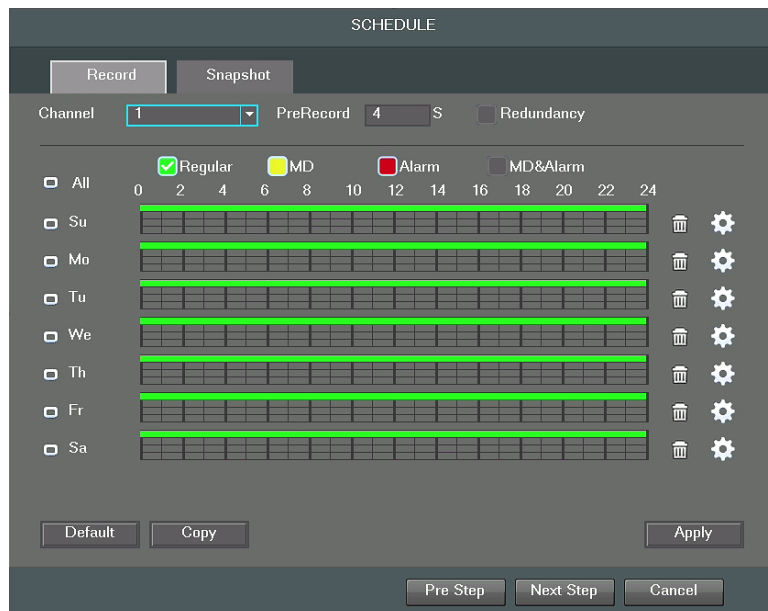

Once you are satisfied with the settings on this screen, click the **Next Step** button at the bottom of the screen.

The next screen that appears is the **RECORD** settings screen. On this screen, you can enable or disable the recording function for Main Stream (HD video – selected by default to record) and Extra Stream (non-HD video – selected by default to *not* record). You can also enable or disable snapshots here (email alerts with snapshots are covered later in this guide).

The screenshot shows the RECORD settings screen. It has a dark grey background and is titled "RECORD". The screen is organized into sections for "Main Stream" and "Extra Stream".

- Main Stream:**
  - Below the title, there are radio buttons for "All", "1", "2", "3", and "4".
  - Schedule:** A radio button is selected, followed by four unselected radio buttons.
  - Manual:** Four unselected radio buttons.
  - Stop:** Four unselected radio buttons.
- Extra Stream:**
  - Schedule:** Four unselected radio buttons.
  - Manual:** Four unselected radio buttons.
  - Stop:** A radio button is selected, followed by three unselected radio buttons.
  - Snapshot:** A section header.
  - Open:** Four unselected radio buttons.
  - Stop:** A radio button is selected, followed by three unselected radio buttons.

At the bottom of the screen, there are three buttons: "Pre Step", "Next Step", and "Cancel".

The next screen that comes up is the **NETWORK** settings screen. *Unless you have a specific reason to change these settings, it's best to leave them as they are.* Network access to the DVR through a computer or mobile app will be covered later on in this guide.

The screenshot shows the NETWORK settings screen. It has a dark grey background and is titled "NETWORK".

- IP Version:** A dropdown menu set to "IPv4".
- MAC Address:** A text field containing "4C:11:BF:36:AA:76".
- Mode:** Radio buttons for "Static" and "DHCP", with "DHCP" selected.
- IP Address:** A text field containing "192 . 168 . 2 . 115".
- Subnet Mask:** A text field containing "255 . 255 . 255 . 0".
- Default Gateway:** A text field containing "192 . 168 . 2 . 1".
- Preferred DNS:** A text field containing "192 . 168 . 1 . 254".
- Alternate DNS:** A text field containing "192 . 168 . 2 . 1".
- MTU:** A text field containing "1500".
- LAN Download:** A checkbox that is currently unchecked.

At the bottom of the screen, there are four buttons: "Default", "Pre Step", "Next Step", and "Cancel".

Once you are satisfied with the settings on this screen, click the **Next Step** button at the bottom of the screen.

The last screen that appears is the **P2P** settings screen. This will be enabled by default. It is highly recommended to keep this enabled if you want to use you're the Amcrest View mobile app or AmcrestView.com to view your cameras remotely.



Once the setup process is finished and you have clicked the “Finished” button, you should see the below dialog box:

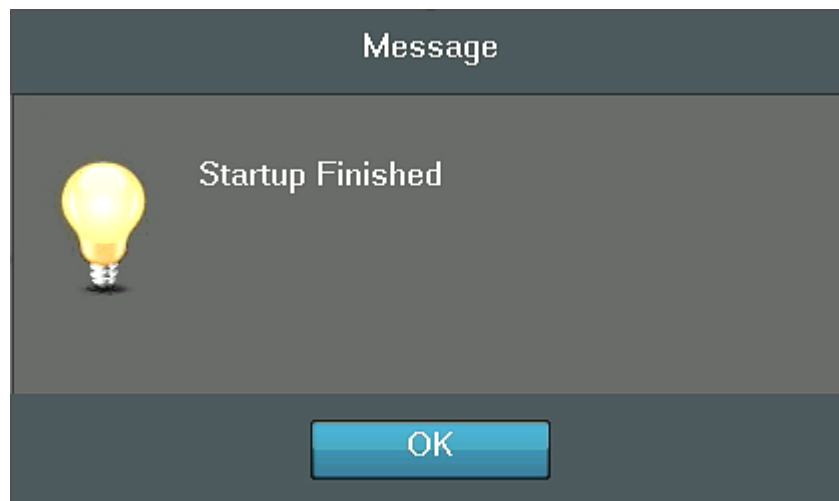

Click OK to continue and the next screen you will reach will be the home 4-window (4-channel) screen for your system.

Before following this guide to the next step, that covers the main menu, you will need to left-click once or right-click and select 'Main Menu' from the right-click menu.

## Main Menu overview

The screenshot below is the main menu screen for the Amcrest DVR console interface:

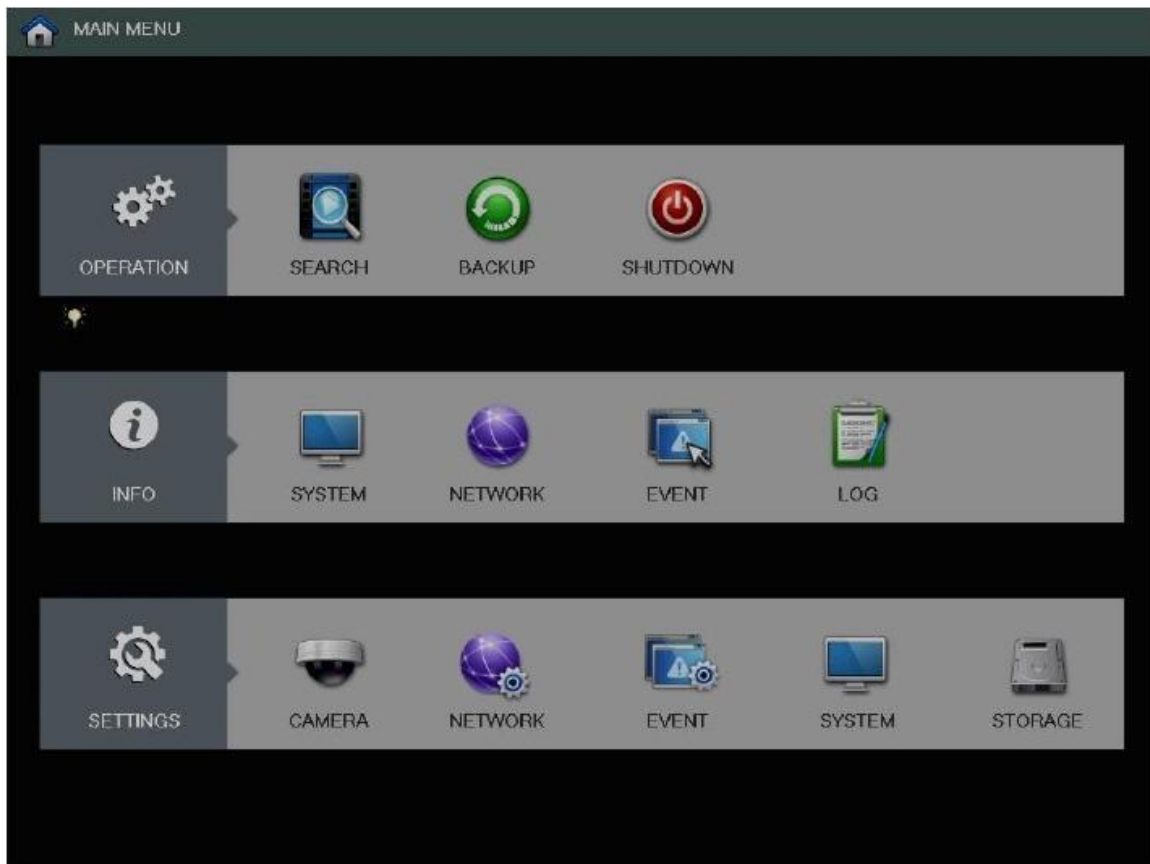

Below are short descriptions for each of the menu items on the main menu:

**OPERATION -> SEARCH:** Search and playback recorded video that is stored on the hard drive.

**OPERATION -> BACKUP:** Backup recorded files onto a USB drive.

**OPERATION -> SHUTDOWN:** Logout, shutdown, or restart the system.

**INFO -> SYSTEM:** View information about the recordings, hard drive statistics, or version information.

**INFO -> NETWORK:** View information about the network or test the network status

**INFO -> EVENT:** Display information about events that triggered recording.

**INFO -> LOG:** Display system logs of critical events.

**SETTINGS -> CAMERA:** Review or edit settings for each camera, including video settings (e.g. quality, bit rate, color, etc.).

**SETTINGS -> NETWORK:** Review or edit network settings for the DVR (e.g. email, DDNS, UPnP, etc.)

**SETTINGS -> EVENT:** Review or edit settings that trigger recording events (e.g. motion detection, alarm, etc.).

**SETTINGS -> SYSTEM:** Review or edit system parameters or configuration, including account settings (e.g. usernames, etc.).

**SETTINGS -> STORAGE:** Review or edit storage parameters and settings.

## 4. Motion Detection & Recording Setup

This section will cover how to set up your DVR's **scheduled recordings** for both **regular** and **motion detection** recordings. It will also cover how to set up **email alerts with snapshots**.

**Note: The DVR can only be set up to save regular and motion detection recordings if a hard drive has already been installed. However, email alerts with snapshots can still work without a hard drive installed.**

A hard drive is included with every DVR 'kit' purchased. You can confirm this by looking at the packaging. If bought as a *standalone* DVR, a hard drive will need to be purchased separately. Once purchased separately, for hard drive installation instructions, please refer to part 3 of this guide: **Console Setup > Hard drive installation**.

The following setup processes will be shown using the DVR console's built-in interface. However, these same steps can also be done through the web interface on a computer. Despite the difference in appearance, the settings pages have the exact same organizational structure.

When motion detection has been set up correctly on this system, you will see the following icon appear on your cameras' live view windows when motion detection has been triggered:



### Setting up recording schedules

1. Log into your DVR with your username and password:

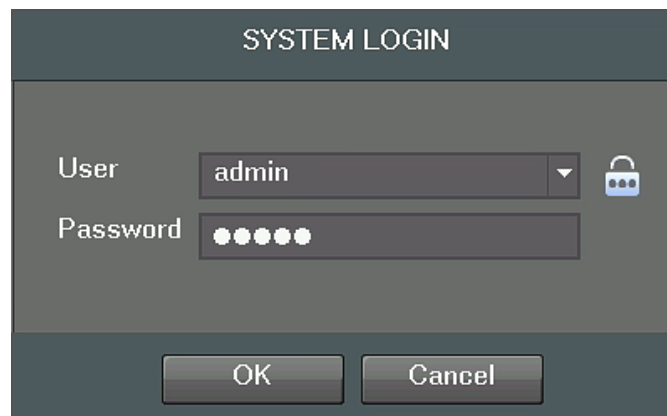

2. Open the **MAIN MENU**, then click **STORAGE** in the **SETTINGS** row:

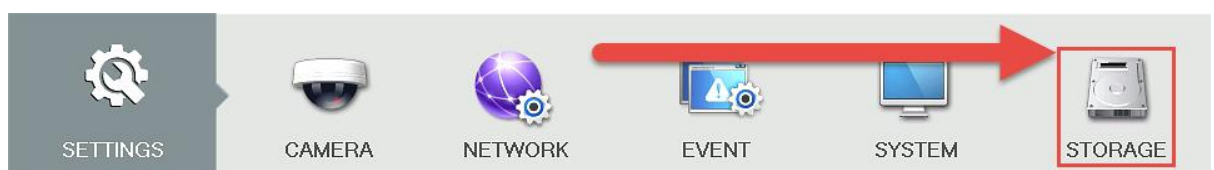

3. Make sure you are on the **SCHEDULE > Record** page. This is where you can configure the times and days you would like different kinds of recordings to happen.

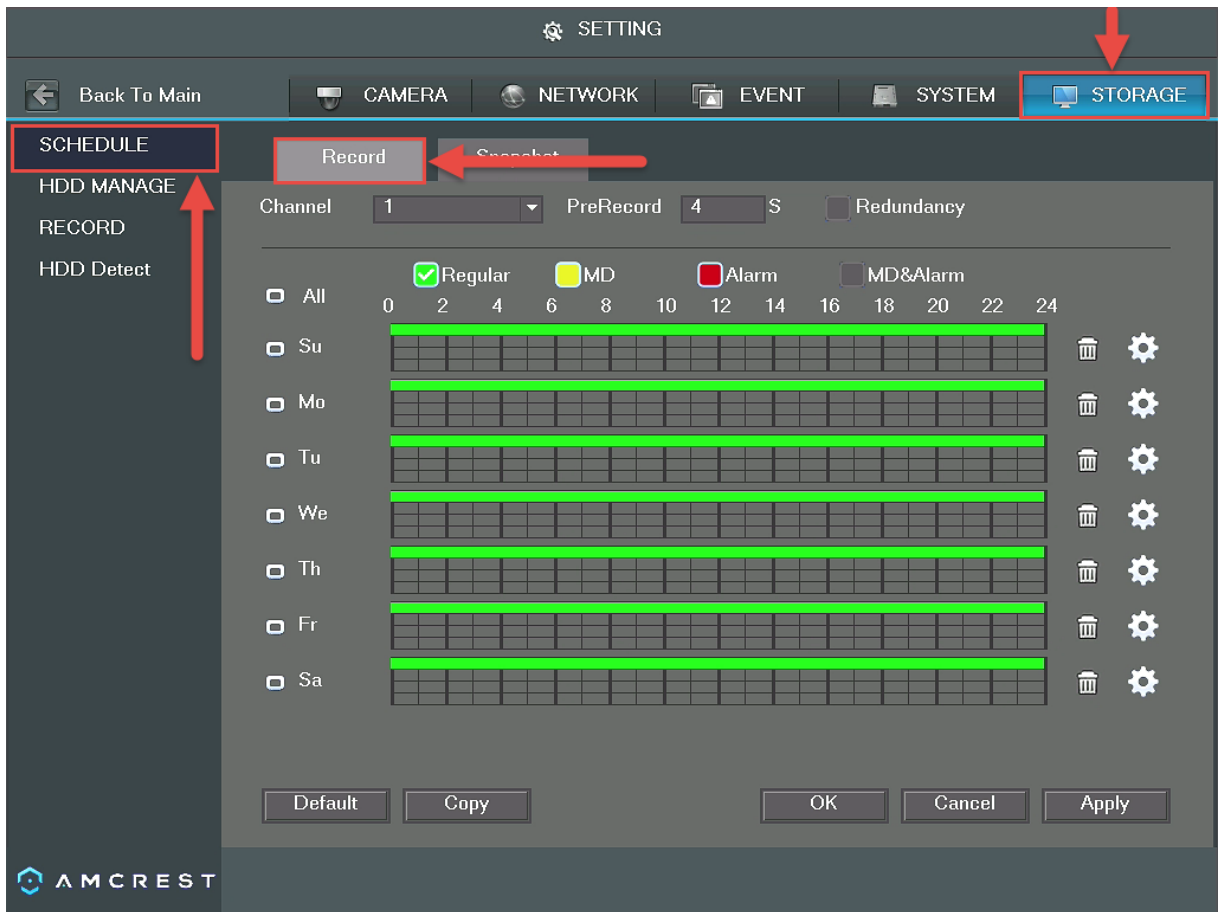

4. To choose a channel (or camera) for which to configure the recording schedules, click the number next to **Channel**, then select either a single channel or **All**:

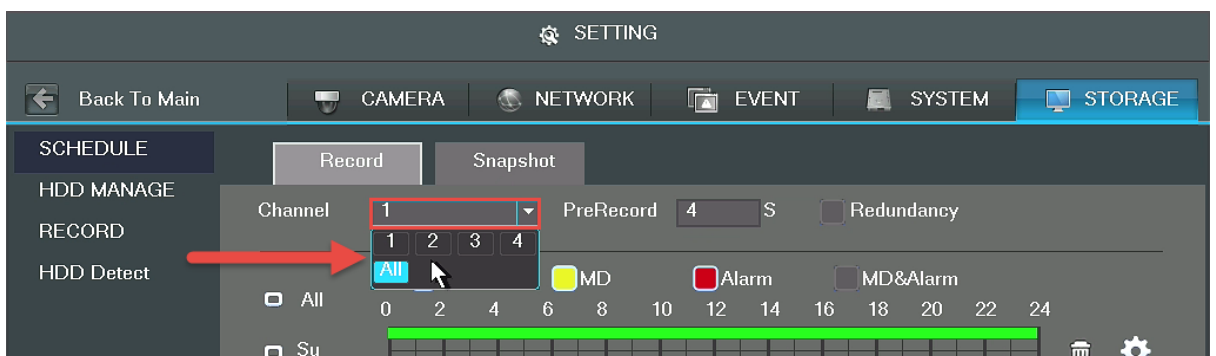

5. By default, the DVR will have the schedule configured to record regularly 24/7. Notice the green bars going across each day of the week. Also note that the DVR uses military time, that is, from 0 to 24 instead of from 12 a.m. to 12 a.m.



To change which hours you would like the DVR to record, make sure the **Regular** checkbox is checked, then click the blocks in the grid. You can also click and drag to add or remove multiple block at a time. Each block represents one hour:

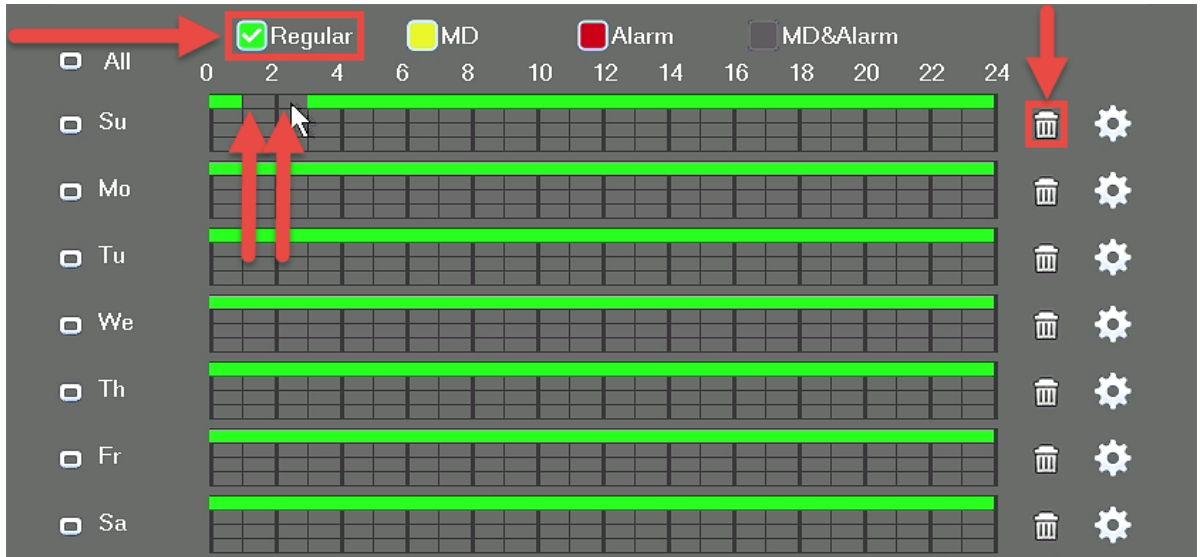

Click the trash can icon to the right of any day to clear the entire row of all green blocks.

6. To add or remove motion detection blocks to the grid, mark the checkbox next to **MD**, then click individual cells or click-and-drag for multiple blocks:



7. To the left of each day, there are small boxes which can be marked to “link” different days together. This is useful if you want to save time by instantly making changes to multiple days simultaneously.

In the below example, Sunday and Monday are linked, so any blocks that are added or removed for Sunday will automatically and immediately reflect the same for Monday and vice versa:

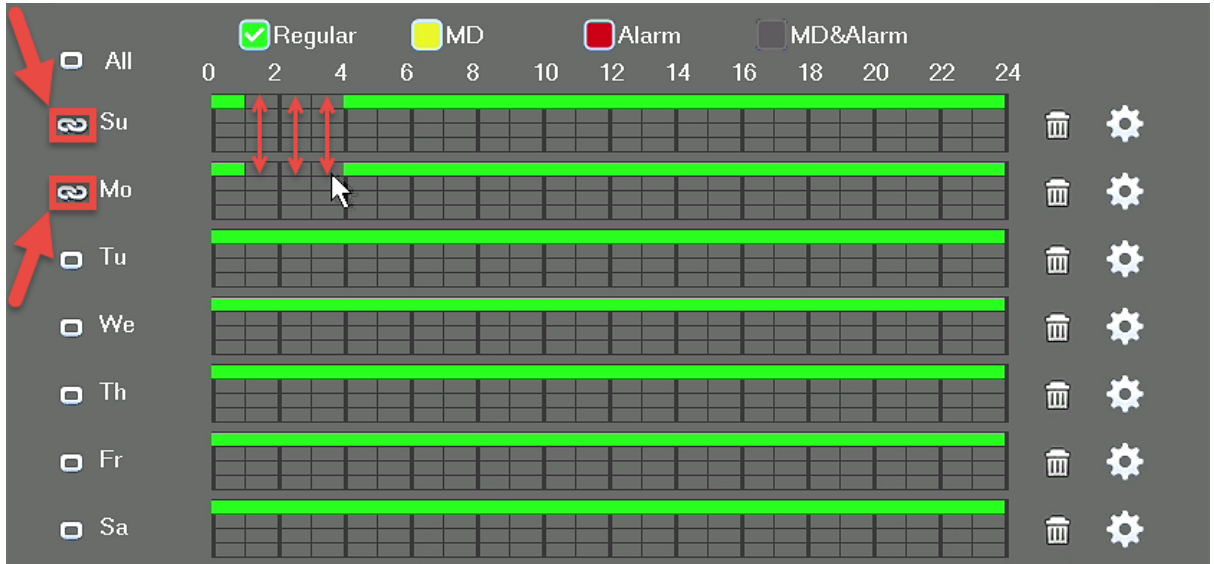

8. Another way to configure recording schedules is by using setting the time periods. Click the 'gear' icon to the far right of any day to open the **Time Period** page:

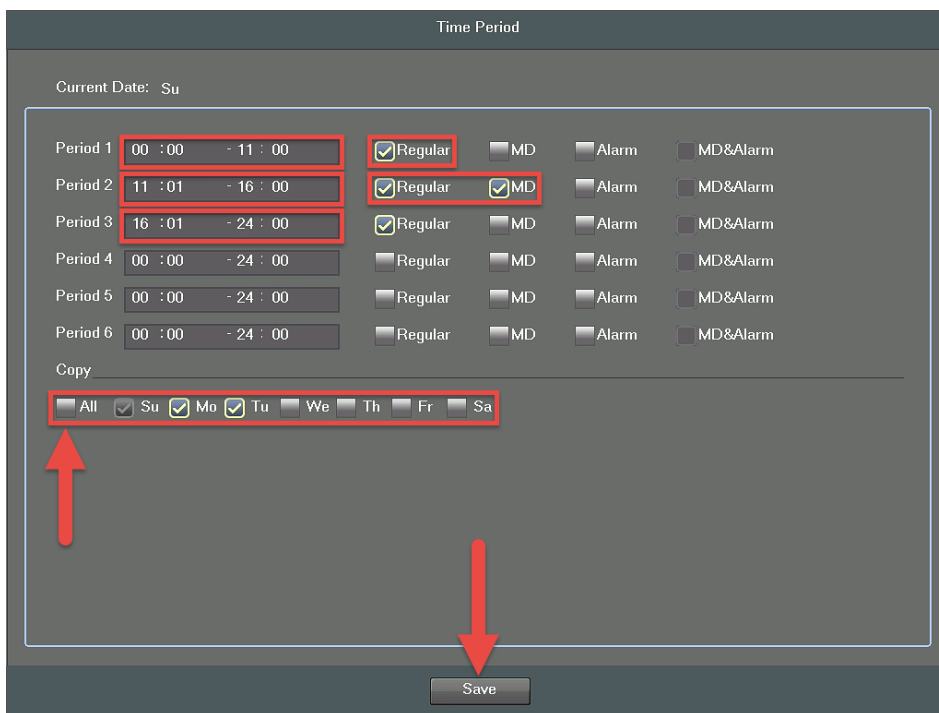

Here, the periods (Periods 1 - 6) must be specified in chronological order. You can set either **Regular**, **MD**, or both with the checkboxes to the right. You can also copy the time period settings over to other days by checking them individually or checking **All**. Make sure to click **Save** when finished.

9. Now that you've finished configuring the recording schedules, you may need to copy these settings over to another channel (or camera). By default, Channel 1 will be selected when you visit this page. Unless you immediately selected **All** in the channel window from step 4 above, note that you can copy these settings directly over to another channel by clicking **Copy** down below:

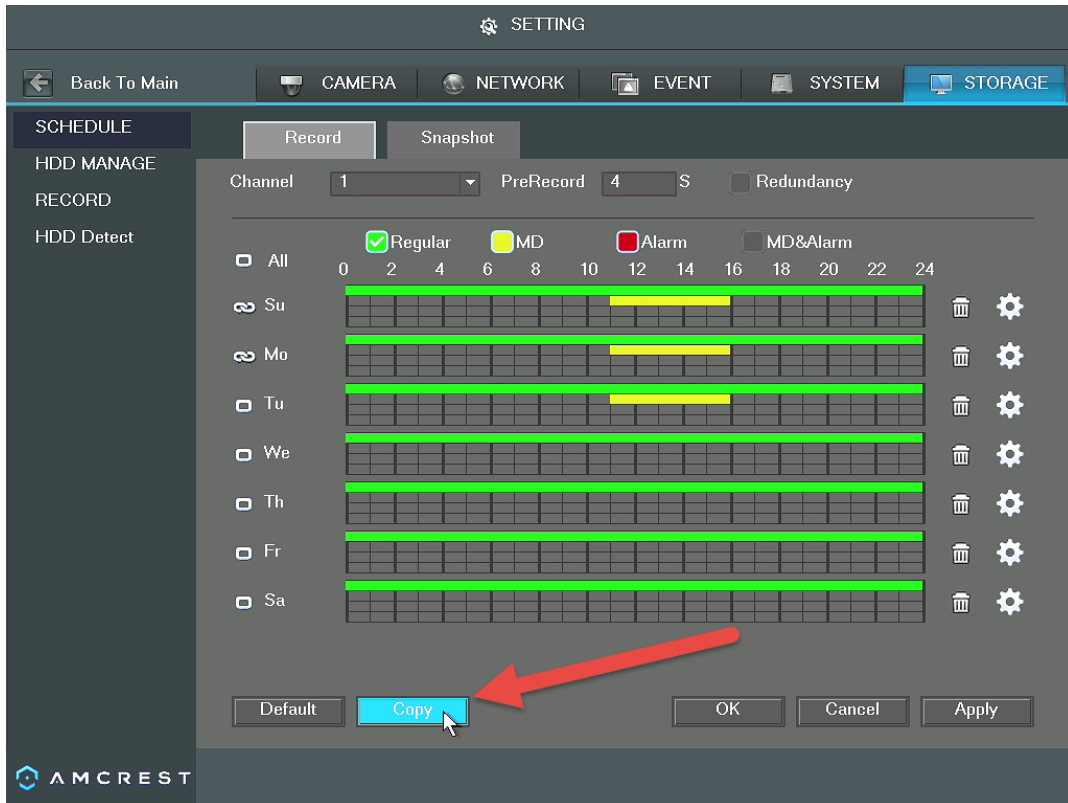

In the **Copy** window, you can select individual channels for any cameras you have added to the DVR or select **All**:

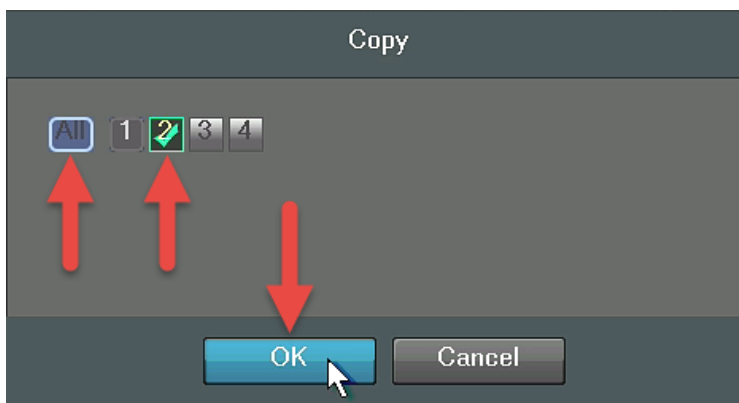

Click **OK** when finished.

10. When finished on this screen, click **Apply** to save your changes.

## Setting up motion detection and email alerts

Your DVR will save motion detection recordings, in addition to scheduled 'regular' recordings and distinguish between the two in the playback menu.

1. Log into your DVR with your username and password:

SYSTEM LOGIN

User: admin

Password: ●●●●●●

OK Cancel

2. Open the **MAIN MENU**, then click **EVENT** in the **SETTINGS** row:

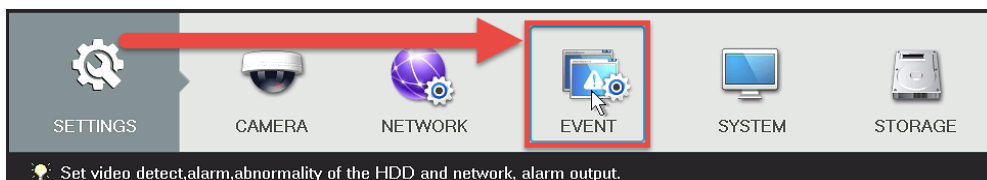

3. Make sure you are on the **DETECT > Motion Detect** page. This is the main configuration page for motion detection:

SETTING

Back To Main CAMERA NETWORK **EVENT** SYSTEM STORAGE

**DETECT** Motion Detect Video Loss Video Masking

ABNORMALITY

Channel: 1 Region: Set

Enable:

Period: Setup Anti-dither: 5 S

Show Message:  Alarm Upload:  Send Email:

Record Channel:

PTZ Activation: Setup Delay: 10 S

Tour:

Snapshot:

Buzzer:

Default Copy Test Save Cancel Apply

AMCREST

Change your channel (or camera) by clicking **Channel** and selecting from any cameras currently added to the DVR. You can also select **All**. Make sure the **Enable** checkbox is checked. Then, click **Set** next to **Region** to configure the motion detection areas.

4. You can set up 'regions' for motion detection using the region grid on your DVR. By default, the entire area of view for your cameras will be highlighted with red blocks. This means that the entire field of view is *active* for motion detection:

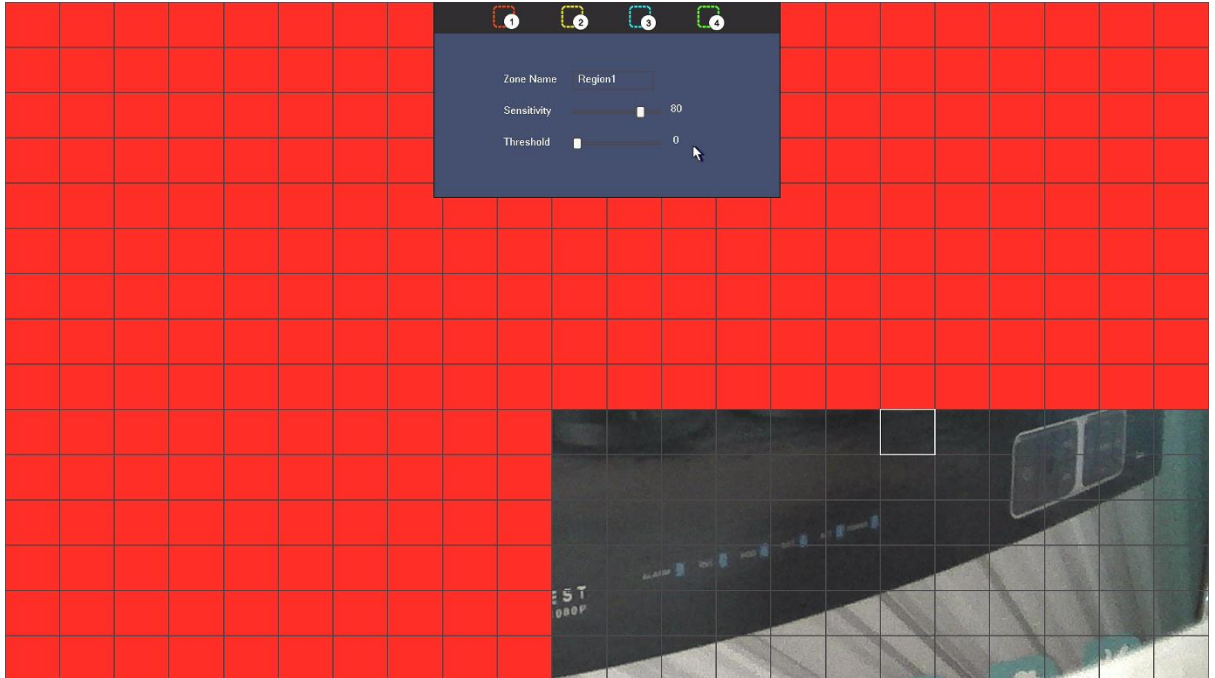

Any red blocks that you click or click-and-drag to *remove* will *not* be active for motion detection. Motion detection will not work for any portion of the screen that is *clear*.

If you hover your mouse pointer over the top-center edge of this window, another small window will appear with options to configure **sensitivity** and **threshold** settings as well as to choose from up to **four regions**.

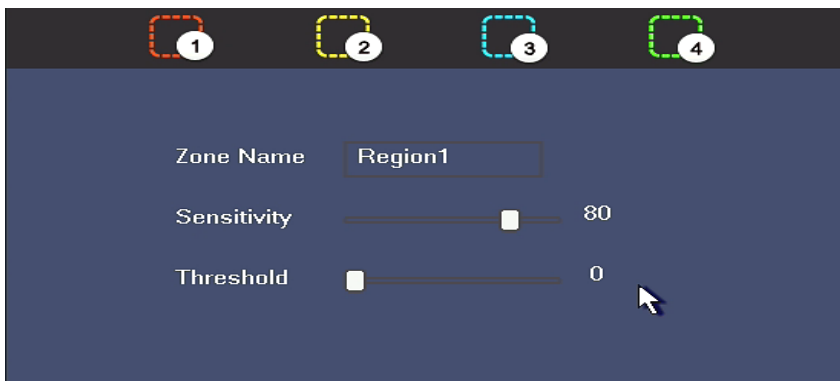

**Sensitivity** - is the measure of how many pixels on the screen need to change before being considered motion. **0** is the lowest value and **100** is the highest.

*In plain English:* Sensitivity is the difference between a squirrel running up a tree, versus a big dog running up to and barking at that tree. A squirrel would trigger motion detection at a *higher* sensitivity because it takes *less change or movement to qualify as motion*. But the dog would trigger motion detection at a *lower* sensitivity because it takes *more change or movement to qualify as motion*.

**Threshold** - is the degree of movement that needs to occur before the motion is defined as a motion event and is triggered. **0** is the lowest value and **100** is the highest.

*In plain English:* Threshold is the difference between a car driving quickly by on a street and a car driving into the field of view, slowing down, and turning into a driveway. The car driving past *would not* trigger motion detection based on a certain threshold setting, but the parking car *would* trigger motion detection with that *same* threshold setting. The *higher* the threshold, the *more time* motion needs to occur before motion detection is triggered. The *lower* the threshold, the *less time* motion needs to occur before motion detection is triggered.

If sensitivity is set to 100 and threshold to 0, motion detection will be triggered *most easily* by almost any change in the field of view, large or small. But if sensitivity is set to 0 and threshold to 100, motion detection will be extremely difficult to trigger.

The **four regions** are all different colors so you can customize the field of view of any camera to your highly specific preferences.

5. To choose another region, hover your mouse pointer near the top-center of the region window, and a small window will appear. Keep your mouse pointer inside that small window and select either region 2, 3, or 4:

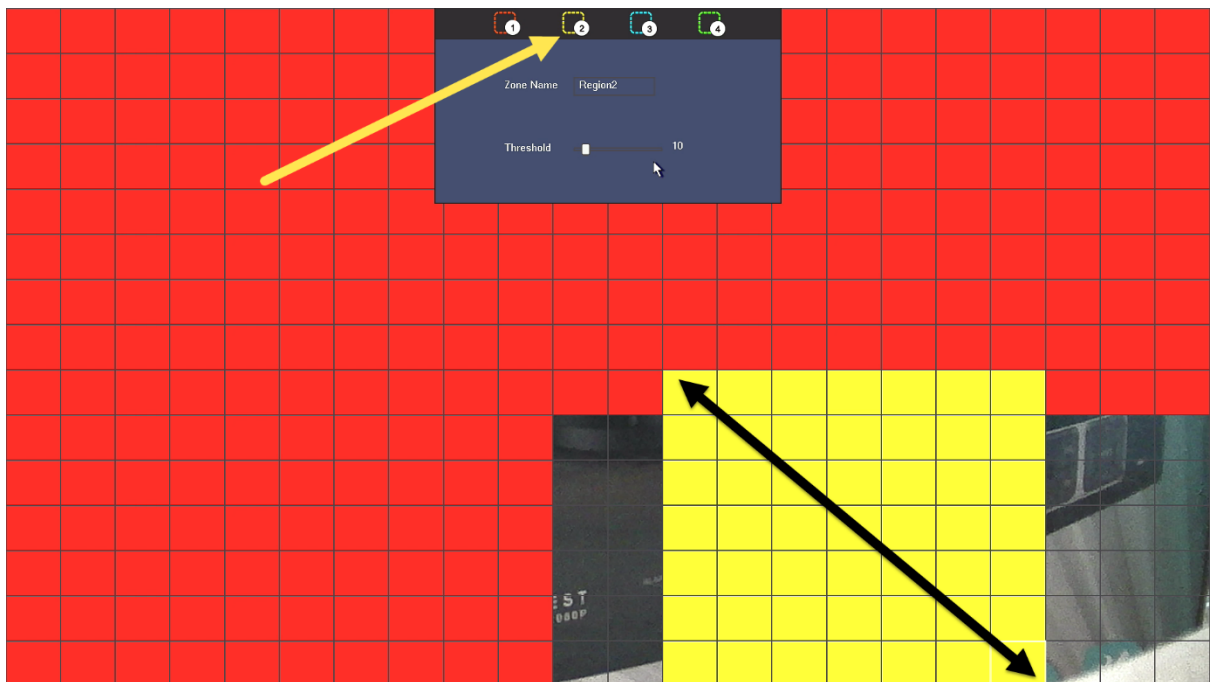

You will be able to click individual blocks or click-and-drag an area with the new selected color to highlight portions of the screen. Each new region (or color) has its own unique sensitivity and threshold settings. The different regions/colors can also overlap one another.

6. You can also adjust the motion detection schedules directly from this settings page by clicking **Setup** next to **Period**:

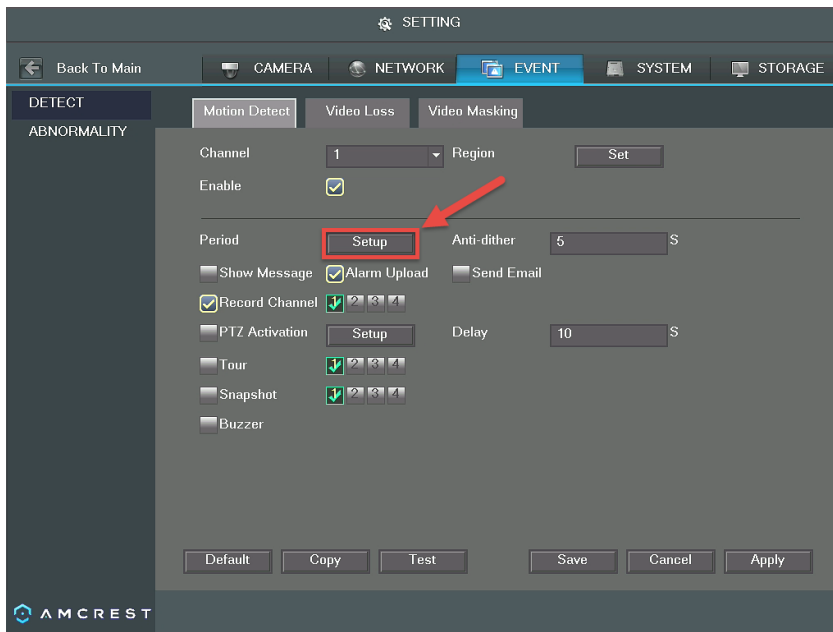

The **Period Setup** page works very similarly to the recording schedule page featured in the previous section in part 5 of this guide: **Motion Detection & Recording Setup > Setting up recording schedules**.

7. Next, if you want to receive **email alerts with snapshots** from your motion detection events, check the boxes for **Send Email** and **Snapshot**:

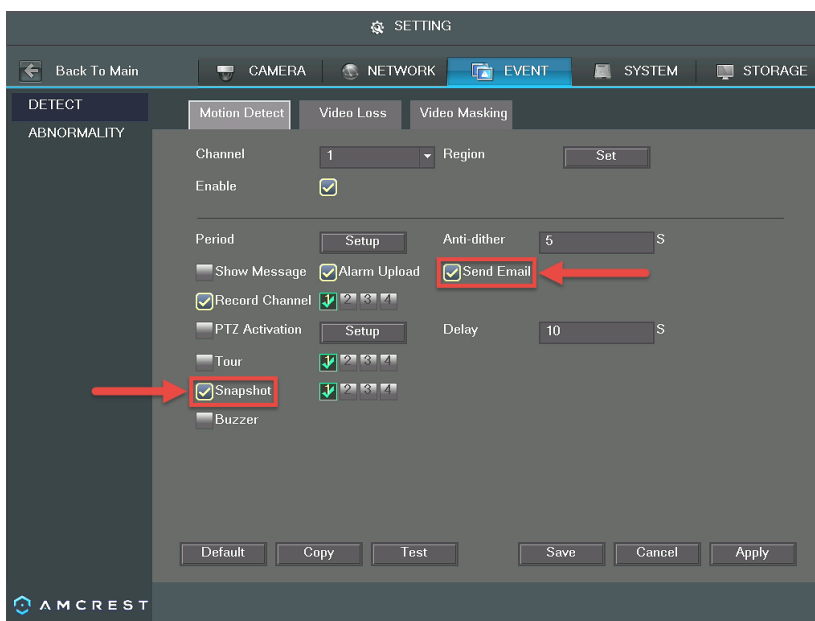

8. Once you have set up your settings for one channel, you can copy them to another channel. If you did not select **All** after clicking **Channel** as described in step 3, click **Copy**, select channels to copy to, then click **OK**:



9. Click **Apply** to save all the settings made on this page, then **Save**.

10. Click the **STORAGE** tab on the top row, then click **SCHEDULE > Snapshot** to get to the snapshot schedule settings page:

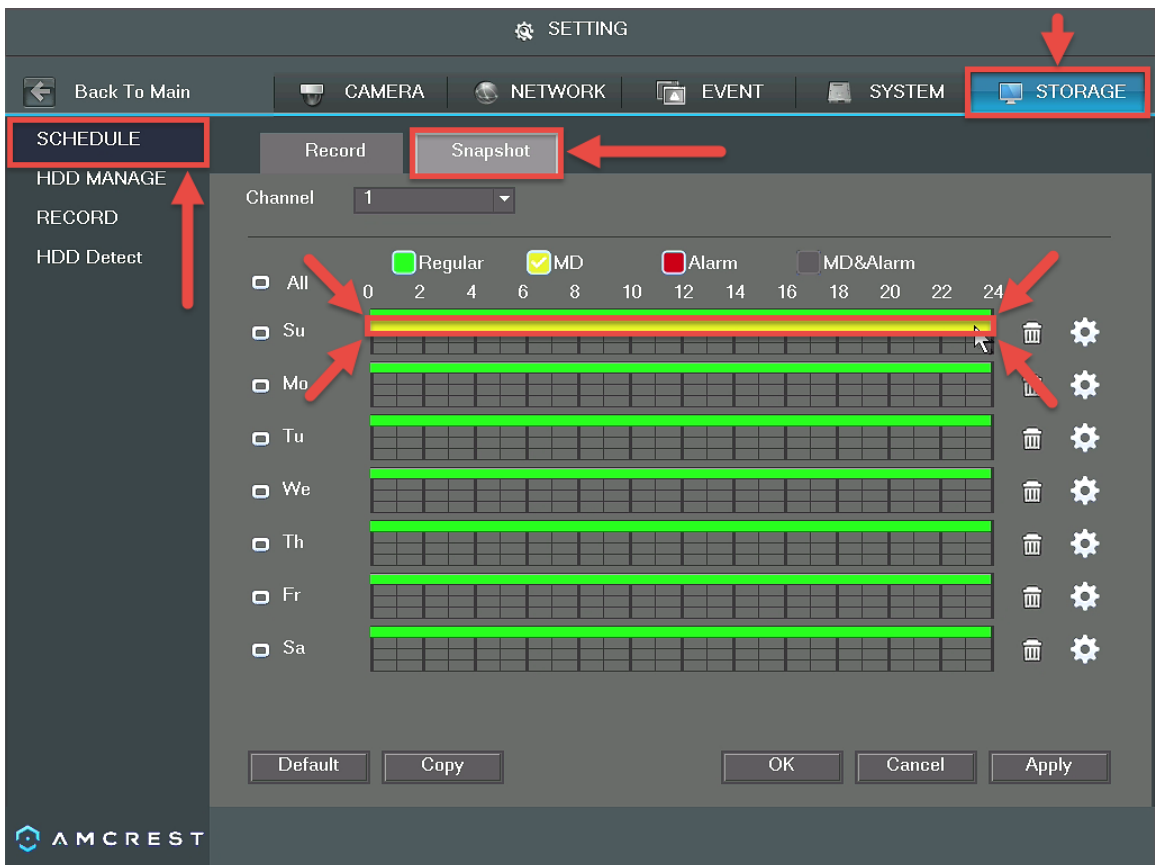

Here, you can set up the snapshot schedule just like you set up the recording schedule. Please refer to the earlier section of part 5 of this guide: **Motion Detection & Recording Setup > Setting up regular and motion detection recording schedules.**



11. Next, click **RECORD** from the left navigation panel, and click the radio buttons under **Snapshot** to enable or **Open** the desired channels:

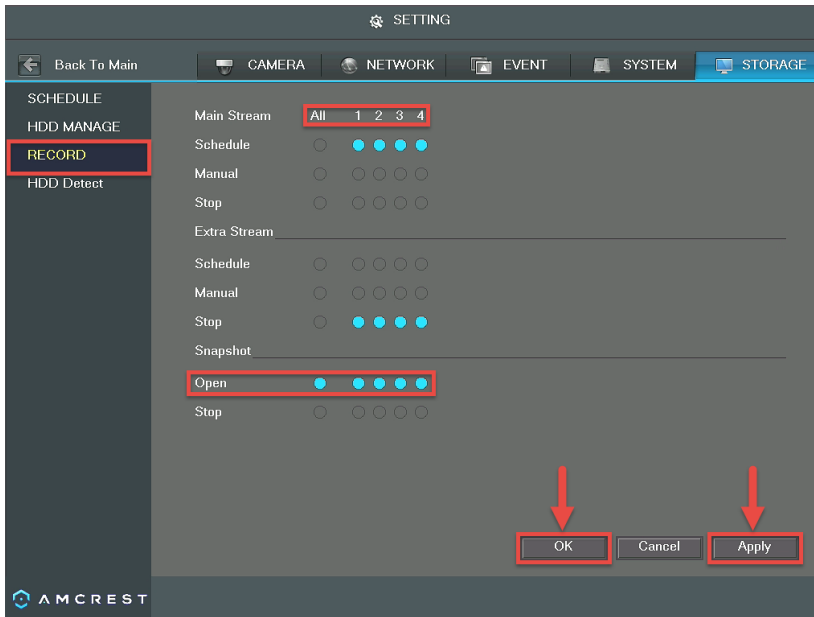

Make sure to click **Apply**, then **OK** before leaving this page.

12. Next, click the **NETWORK** tab on the top row, then click **EMAIL** from the left navigation panel:

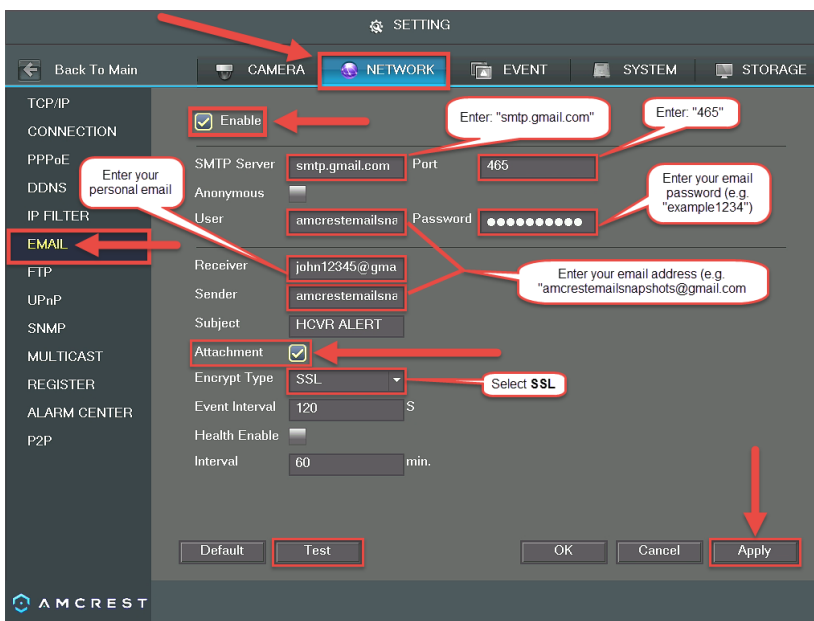

The recommended method for this step is to create a new Gmail account that is dedicated to sending you email alert snapshots for motion detection. This is useful because, then, you don't have to change any of your own personal email's settings. Using a Gmail account is also the easiest way to set up email alerts which could otherwise be somewhat technical and difficult.

This does not mean that you now have to log into a second, separate email account just to see your email alerts - because this email will forward all your email alerts to your personal email. Regardless, it is still recommended to save your email and password information for this new Gmail account.

Start by making sure the box is checked next to **Enable**. Then, enter the **SMTP Server** which, for Gmail, is: "smtp.gmail.com". The port number will be: "465".

In the **Username** field, enter your new Gmail account's address. For example: "[amcrestemailsnapshots@gmail.com](mailto:amcrestemailsnapshots@gmail.com)". Then, enter the password for this account in the **Password** field.

In the **Receiver** field, enter your own personal email account's address. For example: "[myemail@website.com](mailto:myemail@website.com)".

**Note:** In the above example, the Receiver and Sender fields have the same email address. You can do this as well. However, it is recommended to enter your personal email in the Receiver field.

Then, enter your new Gmail account address in the **Sender** field. For example: "[amcrestemailsnapshots@gmail.com](mailto:amcrestemailsnapshots@gmail.com)".

Make sure the box is checked next to **Attachment**. Then, make sure **SSL** is selected in the **Encrypt Type** field.

Finally, click **Apply** in the bottom-right of this window to save all your settings.

13. Now, we want to make sure the email setup is working properly. To do this, click **Test** in the bottom-left. If the setup was successful, you will get the "**Mail Test Normal**" pop-up message after clicking **Test**.



14. Next, check your new Gmail account to see if you received the email test:

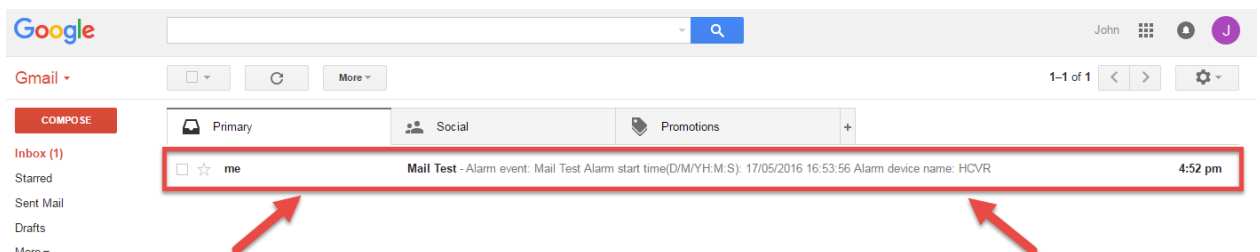

## Computer Access Setup

15. Now, whenever your camera detects motion, you will get email alerts sent to your personal email from this new Gmail account:

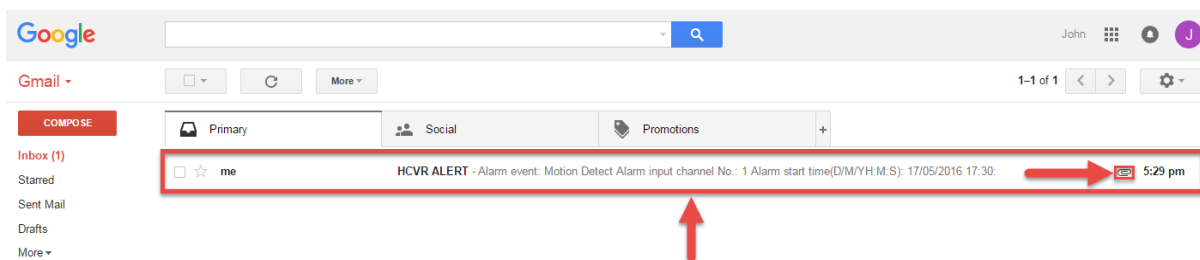

This will include an email with a snapshot of what was seen when motion detection was triggered:

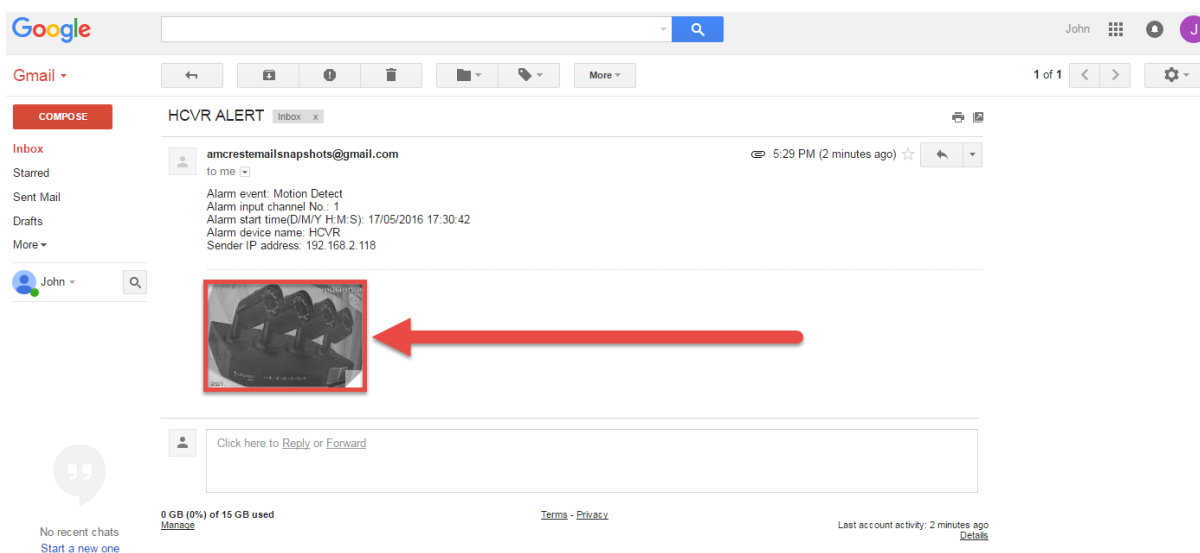

## 5. Computer Access Setup

There are 2 ways to access your DVR from a computer (laptop or desktop) which are: locally or remotely.

**Local Access:** Logging into your DVR's web interface from a computer or laptop device connected to the same network as your DVR (home, office, etc.).

**Remote Access:** Logging into your DVR's web interface from a computer or laptop device connected to a network outside of your home or business network (coffee shop, work computer, etc.)

Local access is preferred by those who, for security reasons or personal preference, do not wish to make their DVR accessible from outside their network. *However, there are several options available for remote access that use standardized and secure network protocols including SSL, TLS, DDNS, etc.* Most other users require remote network access by way of their smartphones, tablets, laptops, or computers, wherever they are.

The following section will cover both means of access (local and remote). Keep in mind that any user can have *both* local *and* remote access simultaneously if they so choose.

**Before accessing your DVR through a web browser, the following two steps must be completed:**

1. You must access the DVR's web interface with its **IP address**.
2. You must install the Amcrest web **browser plugin**.

An **IP address** is just an identifier given to any devices that connect to a network. People use names, but internet-connected devices use a set of numbers called an IP address to talk to each other. Once you have the IP address, your computer will be able to find and communicate with your DVR.

A **browser plugin** is just like a translator. Using your DVR by itself, without a computer (the built-in interface featured in previous parts of this guide) is different than using it on your computer. By using the DVR on your computer through a web browser, you need to introduce a new piece of software that allows your computer to understand the language that the DVR speaks in a way that a computer can understand. That's what the browser plugin is for.

There are 2 ways to access the DVR's web interface: (1) **Amcrest IP Config Software method** and the **built-in interface method**.

## Amcrest IP Config Software method

Amcrest IP Config Software can be installed for free onto your computer from Amcrest's official website. The IP Config Software is available for both Windows and Mac operating systems. To get directly to the downloads page, use this link:

<https://amcrest.zendesk.com/hc/en-us/categories/201939038-All-Downloads>

Otherwise, the steps below will walk you through how to download, install, and use Amcrest IP Config Software:

1. Log onto your computer, open your web browser of choice, and go to [www.amcrest.com/support](http://www.amcrest.com/support):

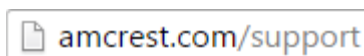

2. Then, hover over the **Support** tab up top and choose **Downloads** from the dropdown.

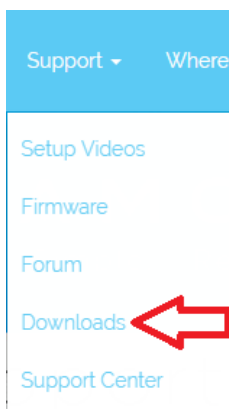

3. This brings you to the downloads page. Click the **IP Config Software** download link on this page for either Windows or Mac.

### All Downloads

Mac OS

[IP Config Software](#) 

PC/Windows

★ [IP Config Software](#) 

4. Find the download in your Downloads folder, and click it to open the installer.

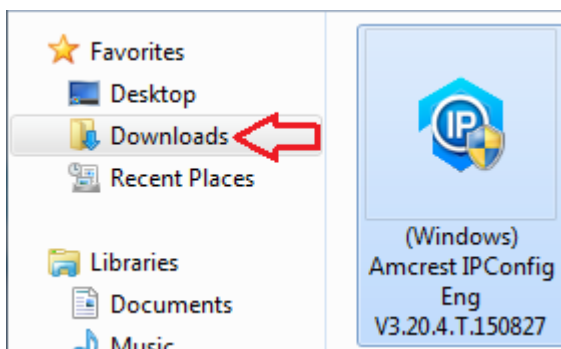

5. You will be asked to allow this program to make changes to your computer with a pop-up window, click Yes.
6. Once you see the first page of the installer wizard, click Next to continue.



7. On the next page, check the box next to "I agree", then click Install.

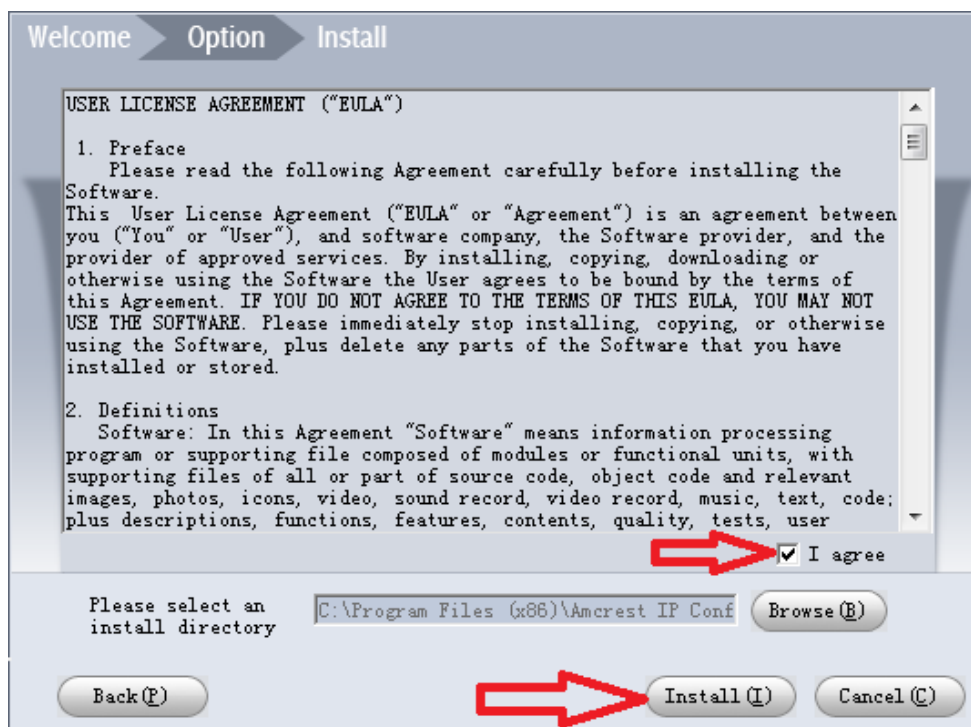

8. After the progress bar completes, if you see a Windows Security Alert popup, click **Allow access**.

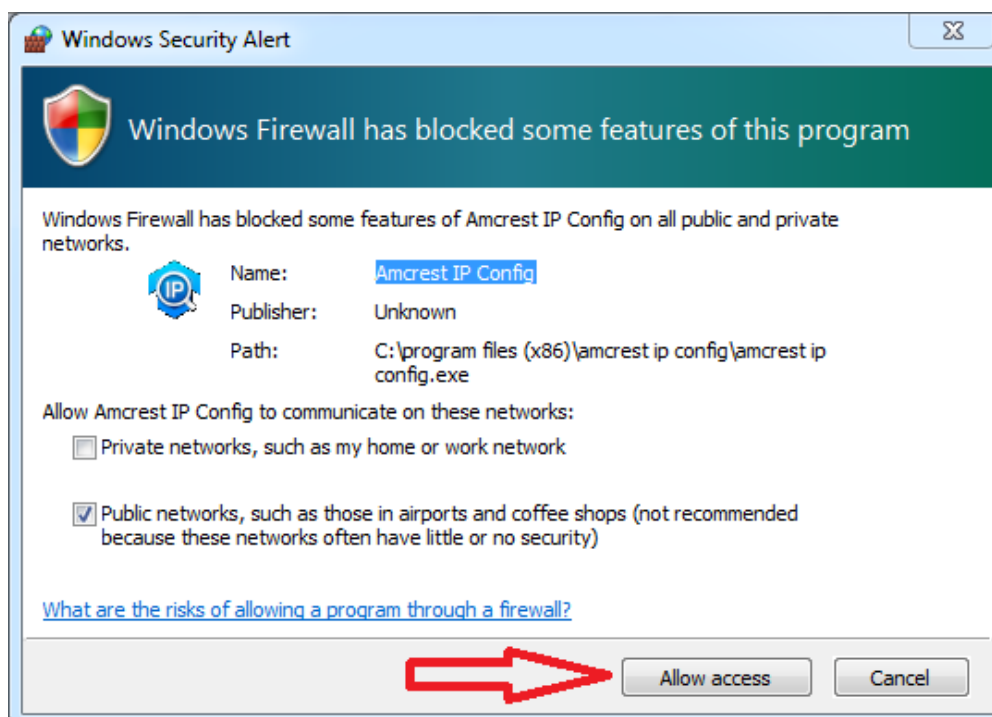

9. This brings you to the main screen of Amcrest IP Config Software. Your DVR will automatically be found on your network and appear in the list (if properly connected with an Ethernet cable to your router). You will also see the IP address associated with your DVR.



The "e" icon to the right allows you to launch directly into your web browser from this screen.

**Note:** This "e" icon will automatically take your DVR's IP address and use your computer's "default" web browser to access and log into your DVR. If your default browser is not Internet Explorer, you can write down the IP address from the Amcrest IP Config Software (IP address located above), open up Internet Explorer yourself, and type that into the search bar to get to the login screen. Typing your IP address directly into the search bar will look something like this:

<http://192.168.1.74/>

## Built-in interface method

1. Boot up and log into your DVR system (as explained in previous steps of this guide).
2. Left-click on the main 4-window screen to access the Main Menu, or right-click and choose it from the list.

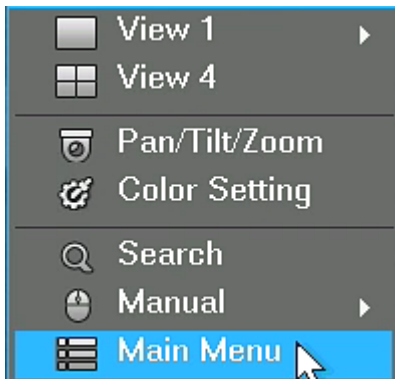

3. Click the **Network** icon, in the third bottom-most row, to the right of **Settings**.



4. On the NETWORK settings page, you will start on the **TCP/IP** tab on the left panel list of options. Locate where it says **IP Address** on the main center page of the window.

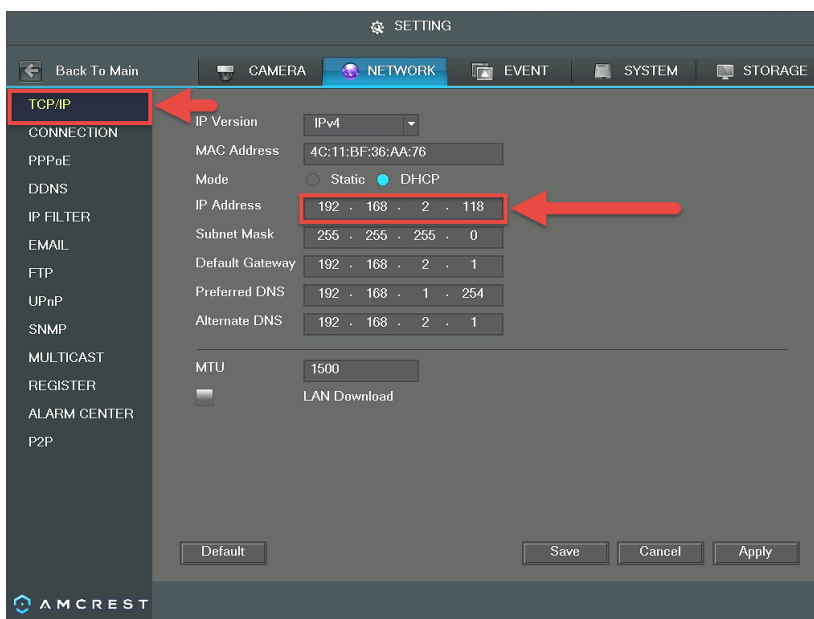



5. Write it down. It will look something like “192.168.1.74”, although it may vary depending on your network, router, or service provider.

**Note:** It does not matter what your IP address looks like. As long as your DVR is connected to your router with an Ethernet cable, and the **DHCP** checkbox is checked on the TCP/IP page, the IP address you write down will be correct.

### Installing the Amcrest browser plugin

Once you've followed one of the above methods to get to the login screen for the DVR, follow the below steps to install the browser plugin on *Internet Explorer*.

1. On the main login screen, you should see a popup in the center. Click **Install**.

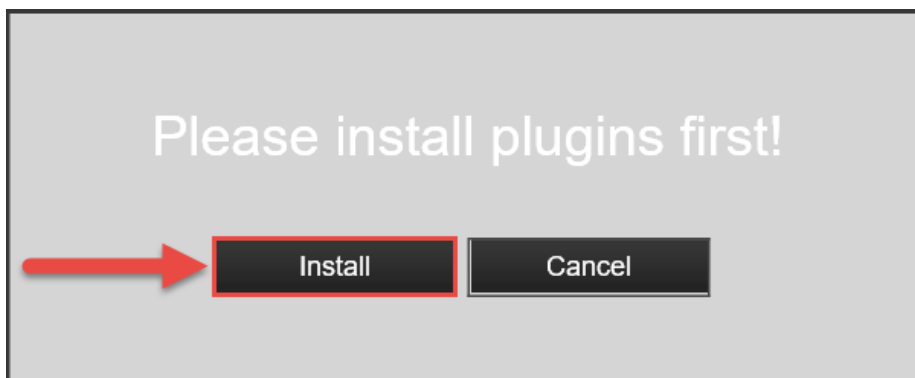

2. An install button will appear on the bottom of the screen for the plugin: **webplugin.exe**.



Click **Run**, then go through the prompts of the install wizard.

3. Once you see the notification along the bottom row. Click the small arrow to the right of the **Allow** button, and select **Allow for all websites**.



4. If you see a popup window asking you to allow the plugin, mark the checkbox next to “Do not show me the warning for this program again”, then click **Allow**.

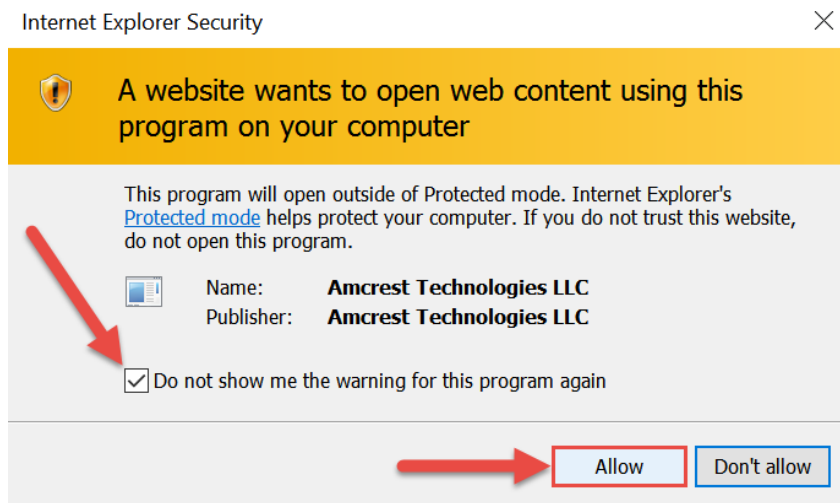

### Setting up DVR Local Access (home or business)

The following procedure can be done one of many ways including: using the Amcrest web interface (the most common method - that should be followed if this is your first time using this system), using the RTSP protocol to pull the video feed into a web application (like a custom website) or standalone program (like VLC media player), or using a CGI command through a web browser for a direct stream (without the need for a website or program - the DVR's CGI commands can be found through the main website - a link to this will be provided in this guide).

For the purposes of this guide, we will cover how to access the DVR through the Amcrest web interface (the most common method).

To view a video on how to setup the DVR for local access on a computer/laptop go to <http://amcrest.com/videos>, click the **Videos** tab, then find the video titled “HDCVI - Local Access Setup for PC”.



Before performing the steps below to gain local access, you will need to make sure the following items are true:

1. You have your **login credentials** (if using this local access method as your first, initial choice to setup your DVR, only items **2** and **3** of this list need to be true)
2. You have located your DVR's **IP address**
3. You have installed the Amcrest **browser plugin**

To find your **login credentials**, please refer to part 3 of this guide: **Console Setup > Logging in**. Otherwise, if this is your first time logging into the DVR and you have skipped **Step 3**, you will be able to login with the following username and password:

**Username:** admin

**Password:** admin

**Note:** After logging in for the first time, you will be prompted to change your password.

To find the DVR's **IP address**, please refer to the **Amcrest IP Config Software method** and the **built-in interface method** sections above.

To install the **browser plugin** for the DVR's web interface, please refer to the above section: **Installing the Amcrest browser plugin**.

1. Take the IP address and type it into the Internet Explorer search bar, then hit 'Enter'. It should look something like "http://192.168.1.74:12345/"

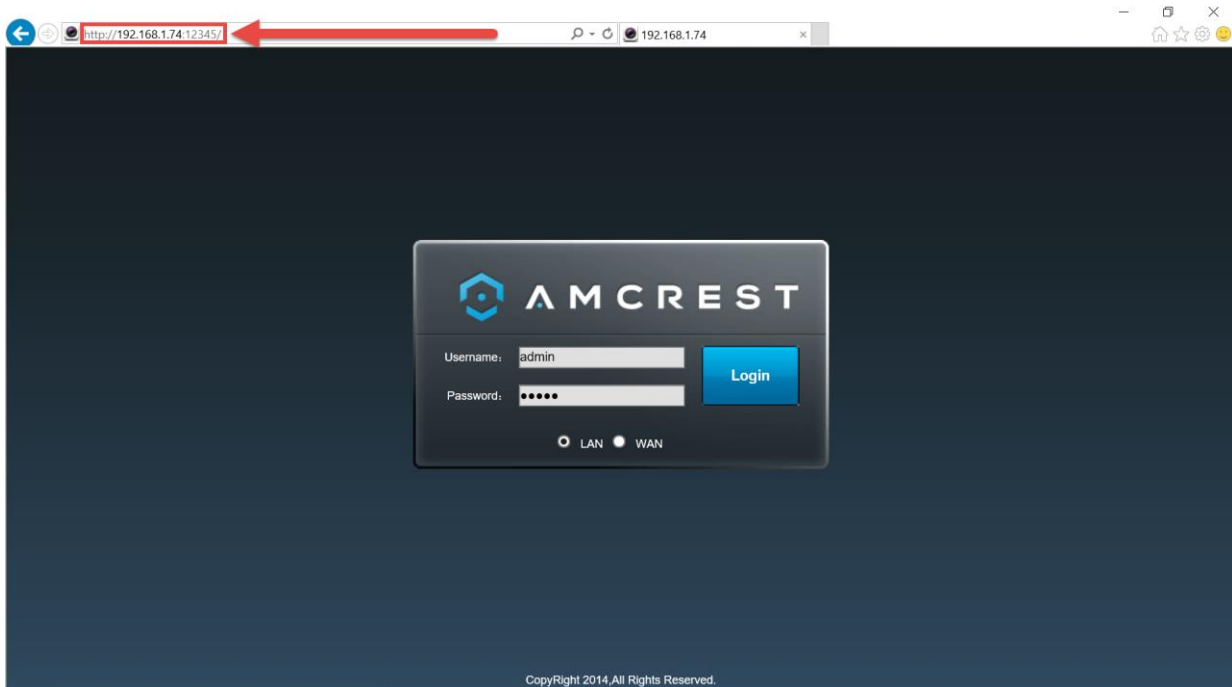

2. Enter your login credentials. You may be prompted to change your password.
3. (Optional) Save this web page as a Favorite for easy access in the future.

## Setting up DVR Remote Access (away from home)

For the purposes of this guide, we will outline the most common method for setting up web access. Using Universal Plug and Play (UPnP) and Dynamic Domain Name Server (DDNS) functionality is the easiest way to setup stable remote access. For this method, your router should support the UPnP networking protocol and the protocol should be enabled. *Please note that most common routers will support this feature.* Please refer to your router's manufacturer documentation to learn how to enable UPnP on your router.

To view a video on how to setup the DVR for UPnP/DDNS remote access go to <http://amcrest.com/videos>, click the **Videos** tab, then find the video titled "HDCVI - Remote Access Setup for PC (UPnP)".



Before performing this setup process, it is recommended that you are familiar with or have completed the steps in both part 3 '**Console Setup**' and part 5 of this guide: **Computer Access Setup > Setting up DVR Local Access**.

Below is a step-by-step walkthrough that details how to setup the DVR for remote web access using UPnP and DDNS:

1. Log in to your DVR's built-in (console) interface, open the Main Menu (by left-clicking once, or right-clicking and choosing **MAIN MENU** from the dropdown), then click **NETWORK** from the **SETTINGS** row:

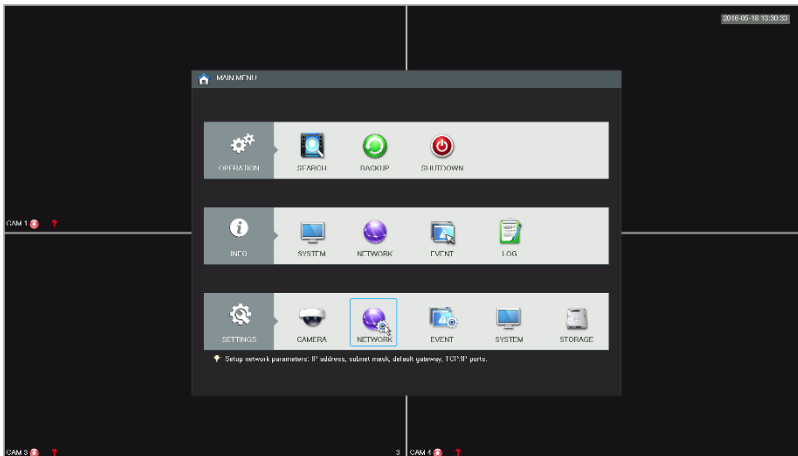

2. From the left hand navigation panel, click **CONNECTION**, then locate the **HTTP port** on the right. It is recommended to ensure the port number is at least 5 digits long to prevent any port conflicts. You can change the port to any 5 digit number that is less than 65535 (e.g. 12345) by clicking the number field, and entering a new port number. Write it down, then click **Apply**.

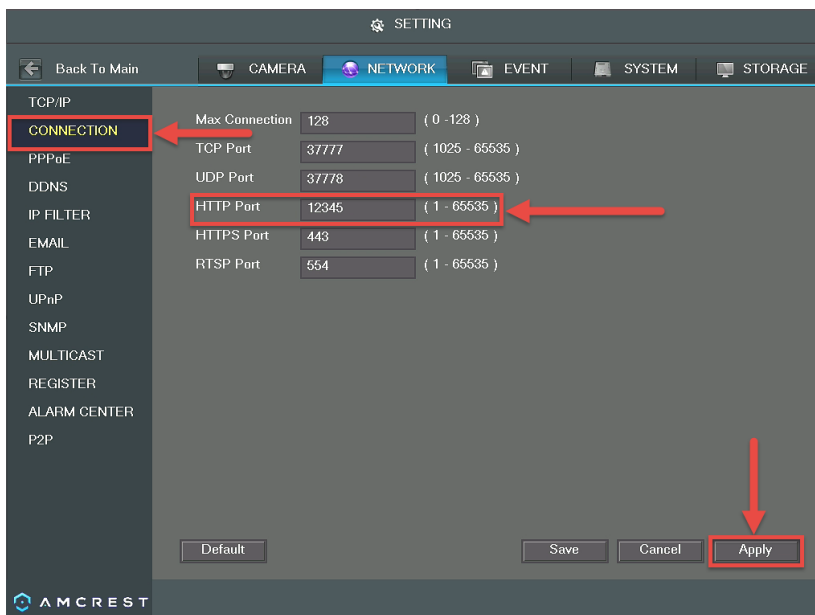

3. The system will need to reboot for this change to take effect. Click **OK**.

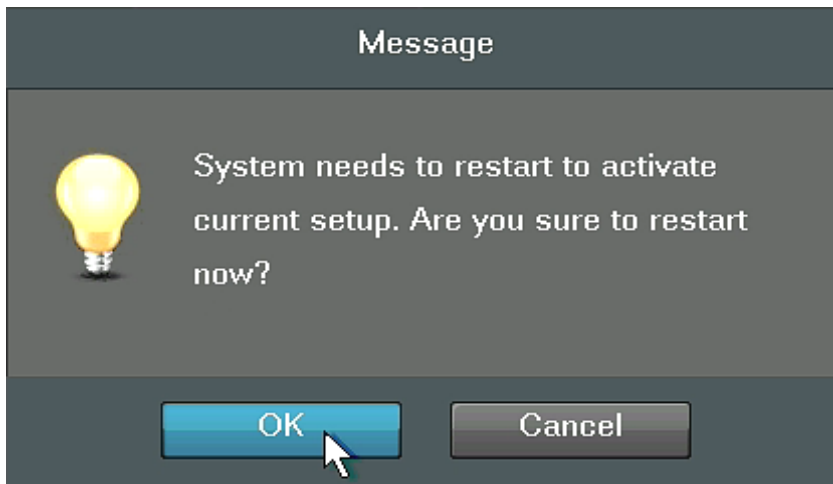

4. Once rebooted, login to your DVR again, open the **MAIN MENU**, then click **NETWORK** under **SETTINGS** again.
5. Click **CONNECTION** from the left navigation panel again, and ensure that the **HTTP port** has changed.
6. Next, click **DDNS** from the left navigation panel, check the **Enable** checkbox.

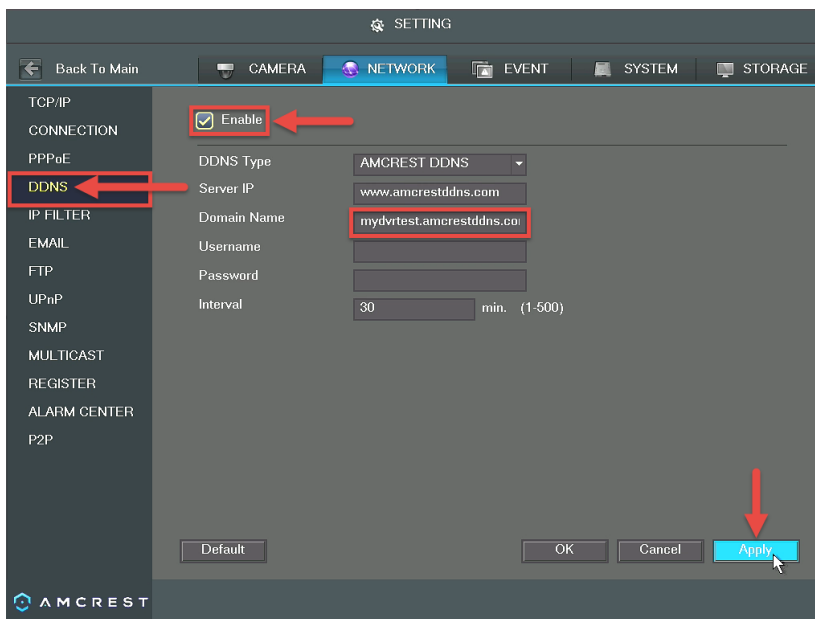

7. Create and write down the entire **Domain Name** field, including the white text that says: .quickddns.com (e.g. "mydvrtest.amcrestddns.com"). Then, click **Apply**.
8. Click **UPnP** from the left navigation panel, and select the **Enable** radio button at the top. Then, locate row **1** in the **Port Mapping List**, where **HTTP** is written beneath **Service Name Protocol**, and click the edit icon to change the HTTP **External Port**.

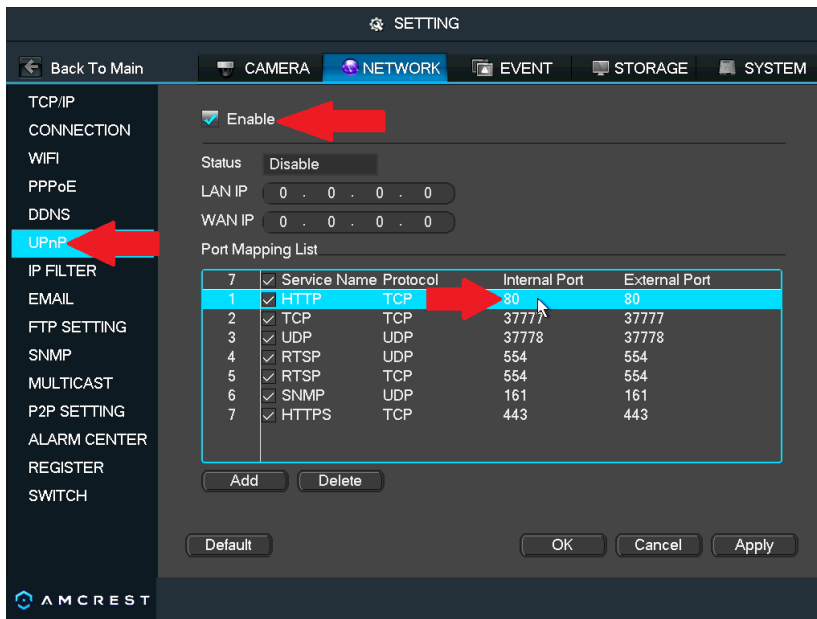

- In the **PORT INFO** window that appears, click into the number field next **External Port** to change it to the same port number that was chosen in step 2 above (e.g. 12345). Then click **OK**.

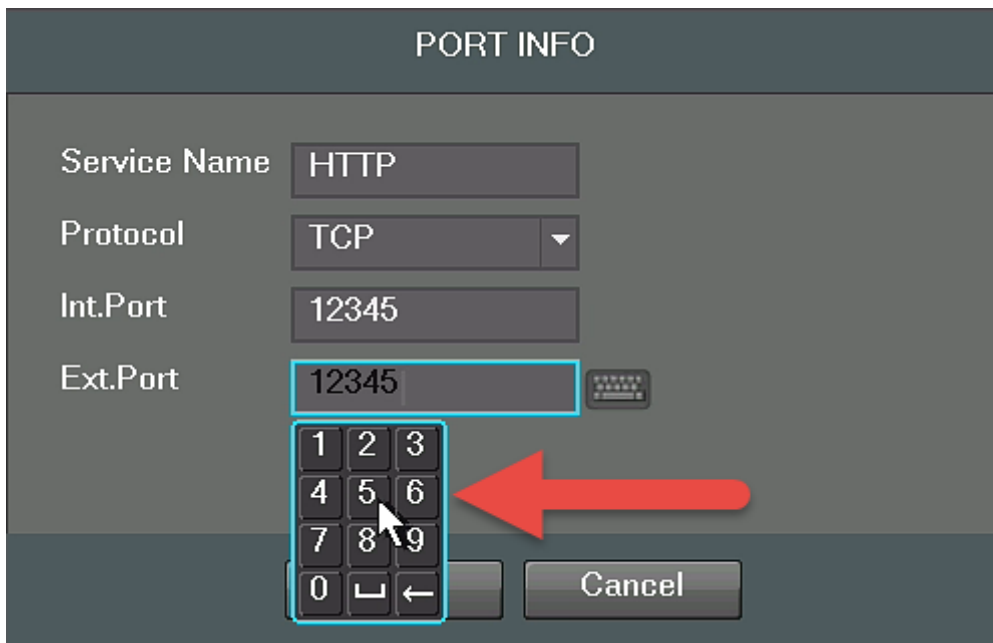

- Now, click **Apply**, and ensure it says 'Searching' in the field next to **UPnP Status**.

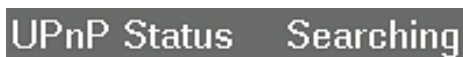

- Exit this menu to go back to the main menu, then re-enter the UPnP menu, and ensure the **UPnP Status** says 'Success'.

**UPnP Status Success**

**Note:** If this does not say 'Success', try resetting the DVR, then your router. If it still does not work, it may be because your router does not support UPnP. In this case, you will need to **port forward** to gain remote access. Please read step 5: **Check for UPnP** below, in the **troubleshooting steps** that follow this guide for more information on what to do next.

- Open a web browser and enter in the DDNS domain name address from step 7, enter in a colon ":" (without quotes), then type the port number from step 2 onto the end.
  - For example, if the DDNS domain name is <http://mydvrtest.amcrestddns.com> and your HTTP Port is 12345, the URL would be <http://mydvrtest.amcrestddns.com:12345>
- The browser may prompt you to install a plugin. Click install to download the plugin, then click on the plugin installation file to install the plugin. (For help installing the plugin, refer to part 5 of this guide: **Computer Access Setup > Installing the Amcrest browser plugin.**)
- Enter your login credentials into the username and password fields.
- Click the **WAN** option, and then click **Login**.



**DVR Web Access**

admin

.....

LAN  WAN

Login

To get more detailed information on other methods to set up remote web access for the Amcrest DVR, please refer to the user manual.

### Remote access not working? (troubleshooting steps)

1. **Re-enter login credentials:** Confirm that your username and password for accessing the DVR are correct. Please refer to part 3 of this guide: **Console Setup > Logging in**. The same credentials you use to log in to the console in that section are what you will enter into the login screen on the web interface.
2. **Use the correct web browser:** Make sure you are using Internet Explorer as your web browser.
3. **Confirm plugin is installed:** If you still see any popup windows when trying to log in to the web interface, please make sure you have correctly installed the Amcrest browser plugin: **webplugin.exe**. Please refer to part 5 of this guide: **Computer Access Setup> Installing the Amcrest browser plugin**.
4. **Write the URL correctly:** When using Internet Explorer, it is crucial to write the DVR's remote access URL correctly. Some versions of Internet Explorer will not automatically include the "http://" prefix to the beginning of an IP address that is typed in. Check your search bar and, if you do not see "http://" before your URL (e.g. 192.168.2.149:12345), please add it. In addition to that, make sure that you are using a *colon* ":" and not a *semicolon* ";". Your final URL should look something like this: "<http://192.168.2.149:12345/>" (without quotes). Keep in mind that the IP address and port number will be different depending on your setup.
5. **Select WAN button:** The **LAN** radio button will be selected by default. You must click and select **WAN** in order for this remote connection to work.
6. **Connect to the internet:** Confirm that your computer is properly connected to the internet by loading another web page first, then trying the DVR's remote access URL again. Also, confirm that an Ethernet cable is connected from your router to the correct port on the back of your DVR. Please refer to part 2 of this guide: **Front/Back Panel Diagrams & Descriptions**.
7. **Check for UPnP:** In order for remote access to work, UPnP has to be enabled on your DVR *and* it has to be enabled and supported on your router. Check your router's documentation to confirm whether UPnP is supported. Otherwise, an alternative to UPnP is **port forwarding** which can be done by following a video tutorial for the HDCVI system. To find this video, go to <http://www.amcrest.com/videos/> and find the video by clicking **Playlists** (tab) > **Amcrest - 1080P & 720P HDCVI DVR > HDCVI - Remote Access Setup for PC (Port Forwarding)**.



**Still not working?**

Please contact Amcrest Support via one of the following options:

- Visit <http://amcrest.com/contacts> and use the email form
- Call Amcrest Support using one of the following numbers  
Toll Free: (888) 212-7538  
International Callers (Outside of US): +1-713-893-8956  
USA: 713-893-8956  
Canada: 437-888-0177  
UK: 203-769-2757
- Email Amcrest Customer Support [support@amcrest.com](mailto:support@amcrest.com)

## Web Interface Walkthrough

The web interface has 3 main tabs:



**Live:** This tab shows live playback of any connected cameras. Ensure that the small icon on the right of each camera's name on the left hand list is blue; otherwise the live video feed will not show. You can also control PTZ and image settings here, as well as view cameras in full screen.

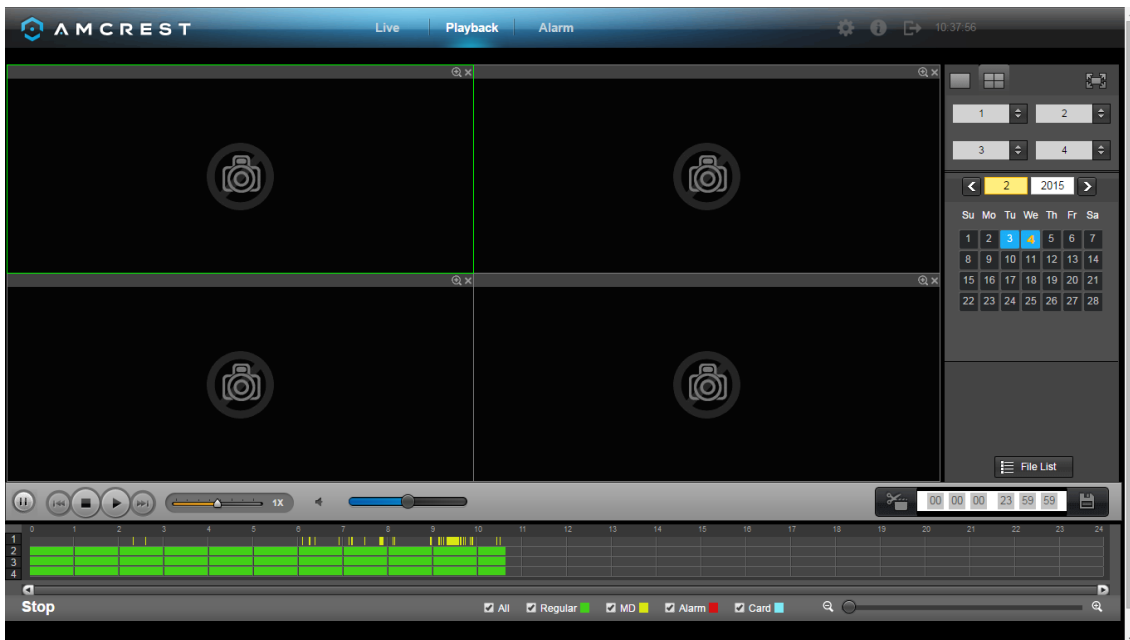

**Playback:** This tab allows for playback of recorded video. Select the date from the menu on the right and then click on the timeline at the bottom of the screen to select a playback starting location. Once the starting point has been selected, hit the play button to begin playback.

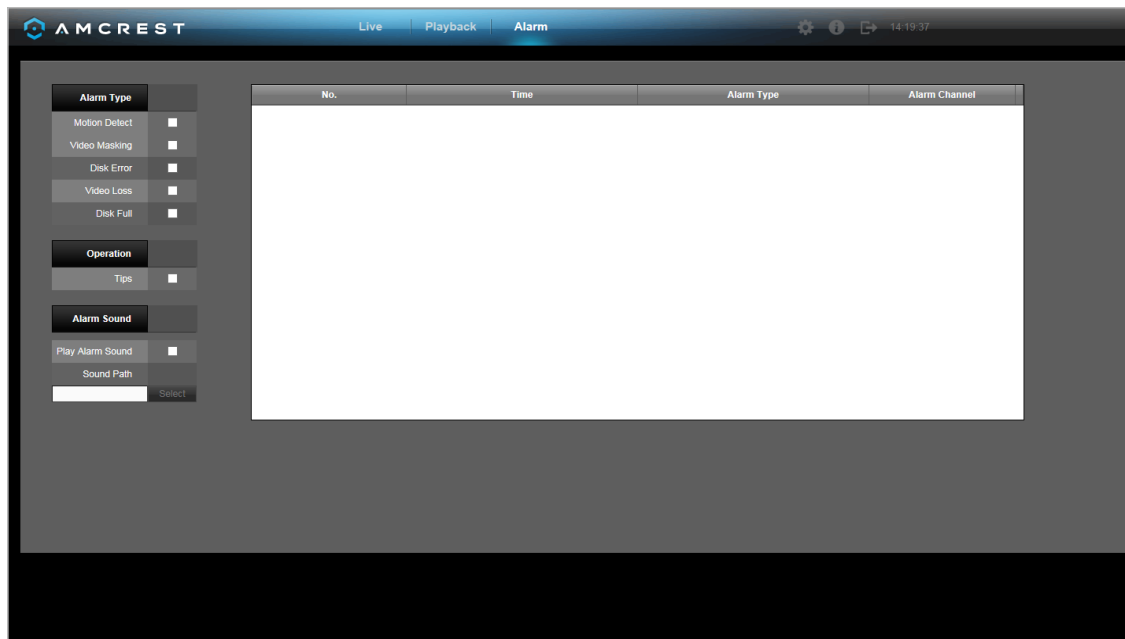

**Alarm:** This tab shows a list of any alarms that have been triggered, either by motion detection, video masking, disk error, video loss, or the disk becoming full.

## 6. Amcrest View App Setup

The Amcrest View app grants instant access to all live camera streams from any location. This is the primary application most users prefer when using Amcrest systems. The app supports a multitude of features and includes both a plug-and-play setup as well as a manual network setup. For purposes of this guide, we will use Amcrest View Pro, which is free on both the App Store and Play Store.

Before accessing the DVR through the app using the easy plug-and-play method (P2P Setup), **confirm that P2P is enabled on the DVR**. This feature should be enabled by default.

### Enabling P2P on the DVR

1. Log into your DVR console's built-in interface using the DVR login credentials. Please refer to part 3 of this guide: **Console Setup > Logging in**.
2. Open the **MAIN MENU** by left-clicking the DVR's home preview screen. Then, click **NETWORK** in the bottom **SETTINGS** row:



3. Select **P2P** from the left navigation panel's list of options. Make sure the checkbox next to **Enable** is checked. If it is not, check it, then click **Apply** and **Save**.

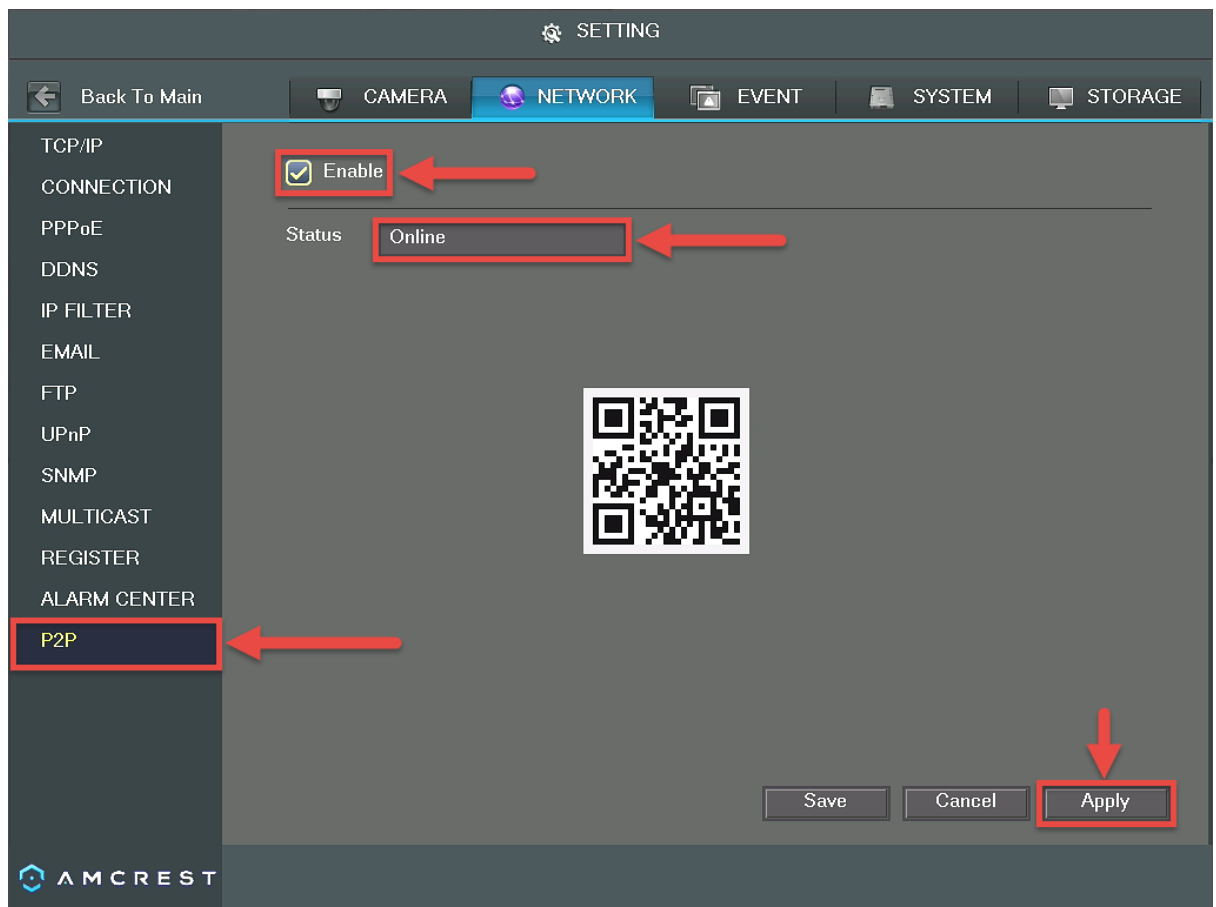

4. Exit out of the main menu, then come back to the **P2P** page and confirm that the **Status** is '**Online**'.

### Amcrest View Pro Setup

The following steps will continue the app setup process for an Android phone and, though the iPhone version of the app has slightly different steps, most of this process is identical and easy.

1. On your Android device, locate and open the Play Store.

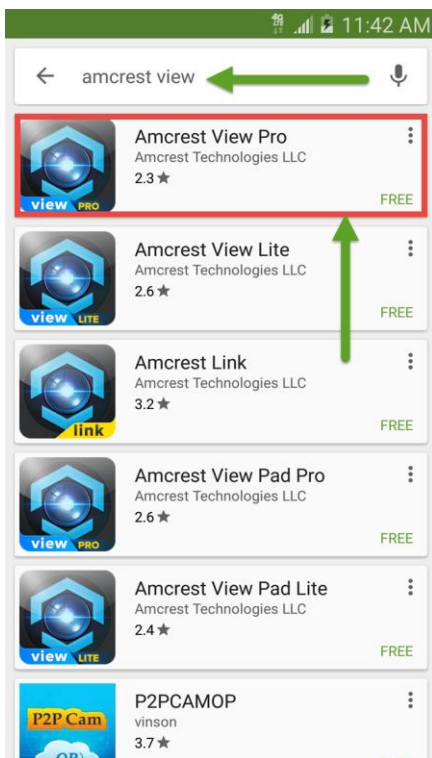
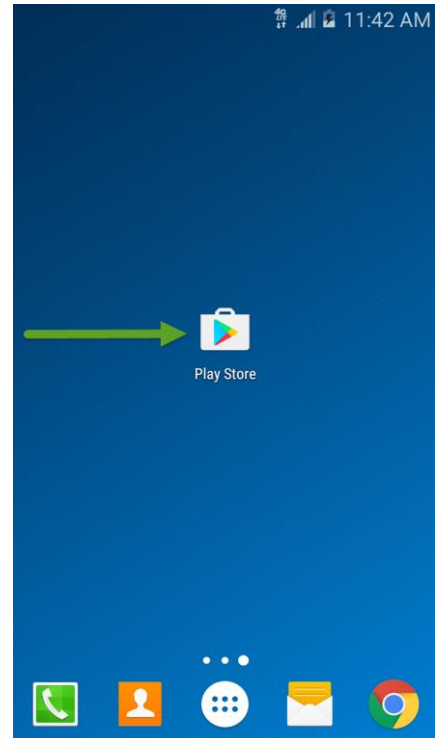

2. Type "Amcrest View" in the search bar, hit enter, then tap **Amcrest View Pro**.

3. Tap **Install** to begin installation.

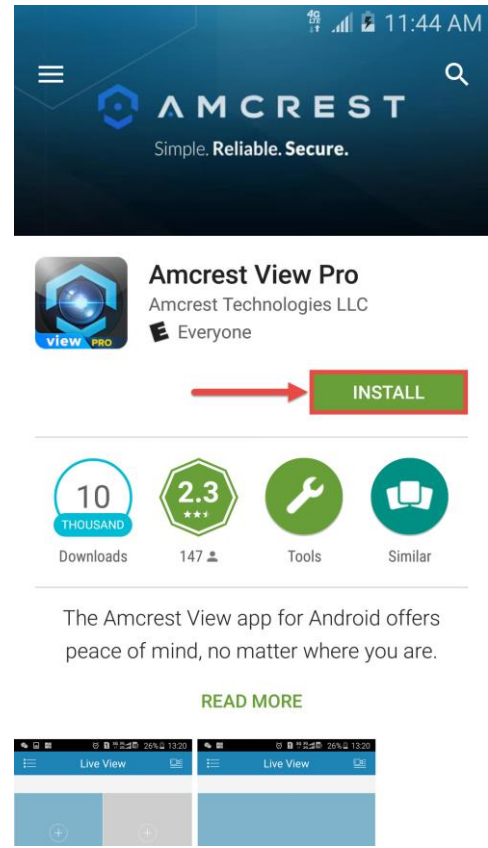

4. Tap **Accept** on the next screen.

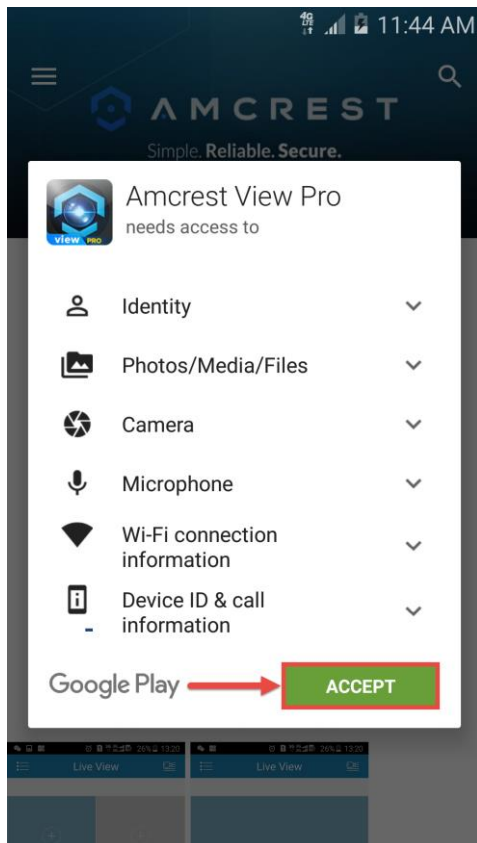

5. When finished installing, tap **Open** to launch the app. You will see some screens appear.

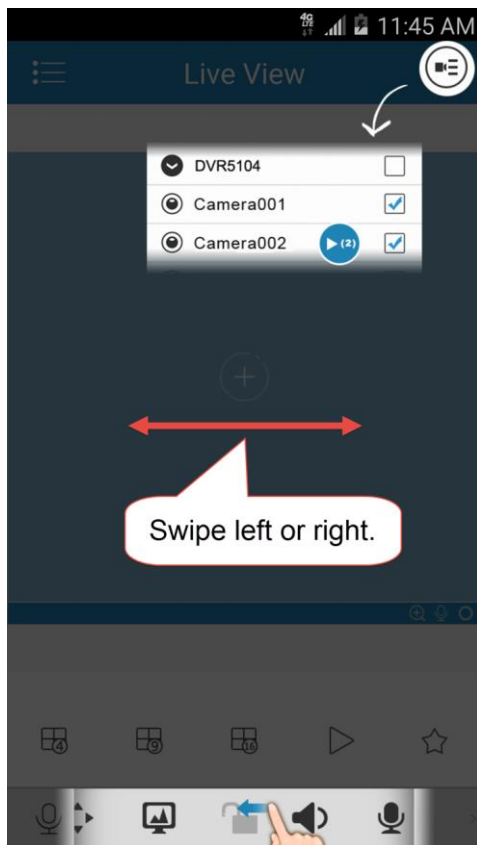
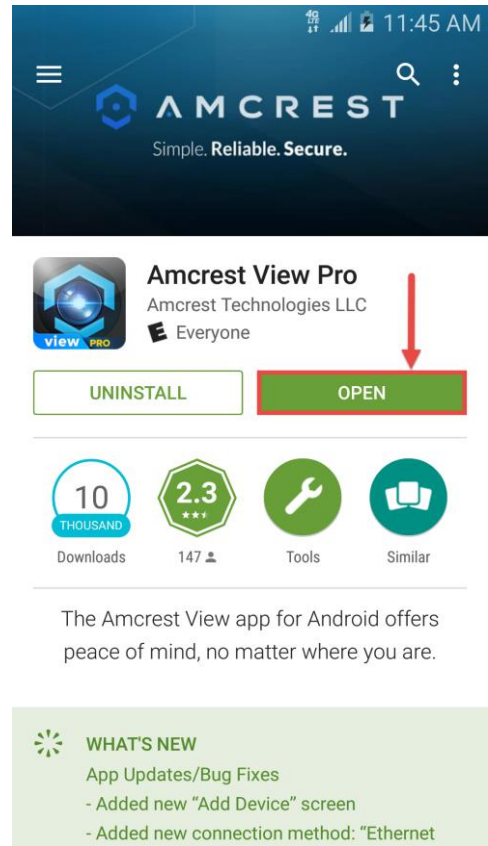

6. When it shows the screens with arrows, you can swipe them out of the way.

7. Now you should see the home screen of your app. Tap the icon in the top-right to get to the **Device List**.

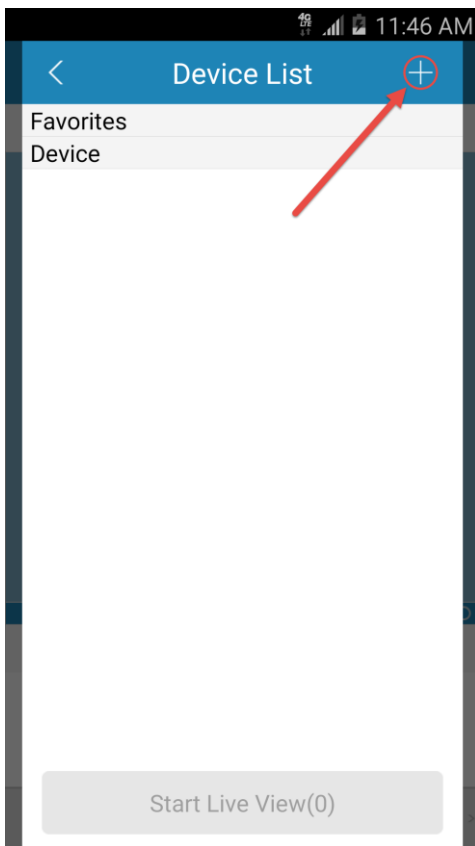
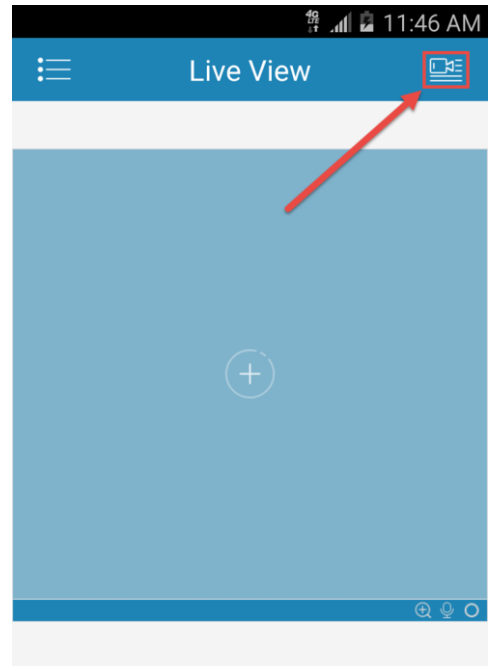

8. Tap the + icon in the top right of this window to get to the Connection Type screen.



- 9. Select **P2P Setup** from the list to get to the P2P Setup main page.

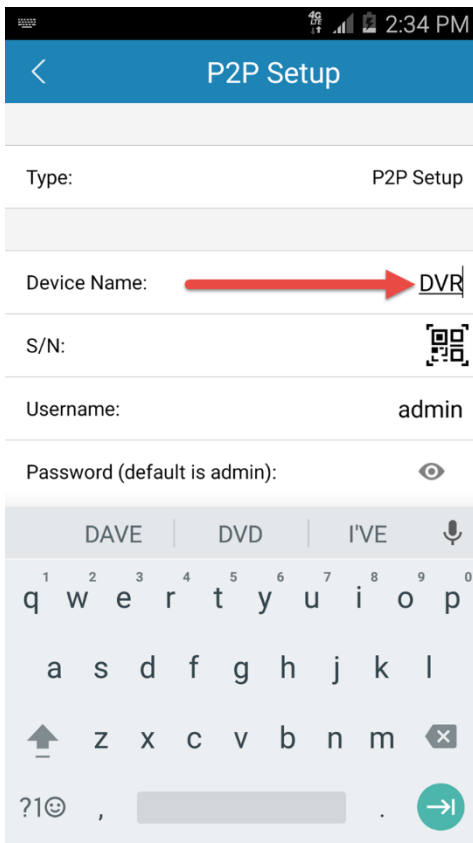
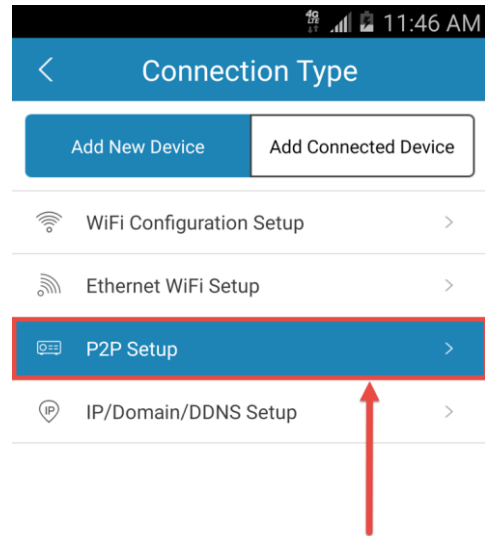

- 10. **Name** your device (this can be any name you want).

11. Next, we need to input the DVR's **serial number**. You can either **scan the QR code** or **enter the serial number manually**.

**QR scan (recommended method - easier):**

Tap the QR code icon in the far right of the S/N field, and it will activate your smartphone's camera:

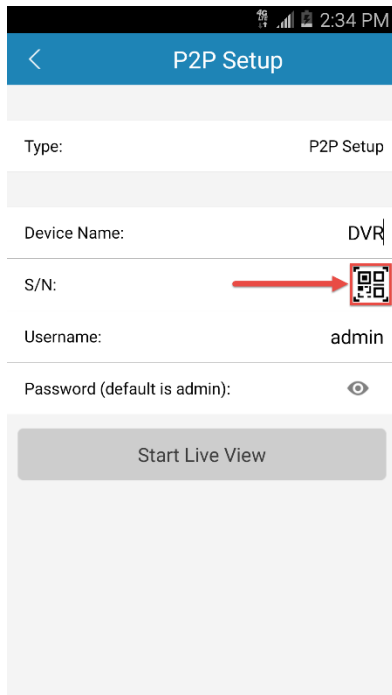

**Note:** the QR code will only scan if positioned entirely inside the clear square in the center of the screen. Once centered, if the QR code still appears blurry, move your smartphone back and forth slowly until the image comes into focus.

Try to center *and* focus the QR code as shown below, to the right.

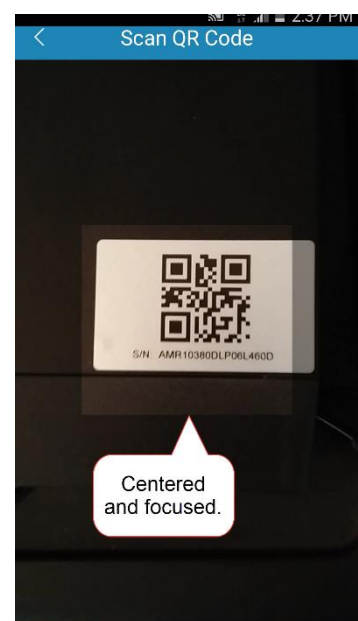
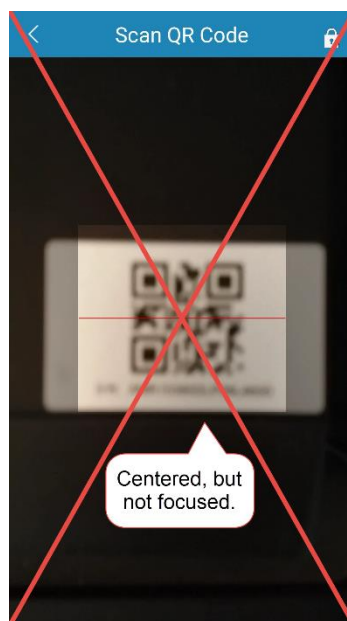
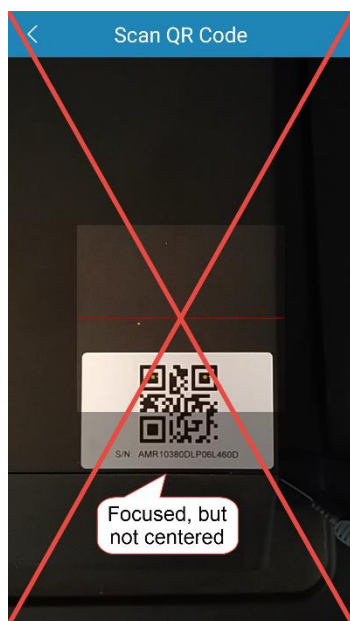

As soon as the QR code is read, your phone will vibrate and the app will automatically take you back to the P2P Setup page where you will notice that the serial number has been automatically populated in the **S/N** field:

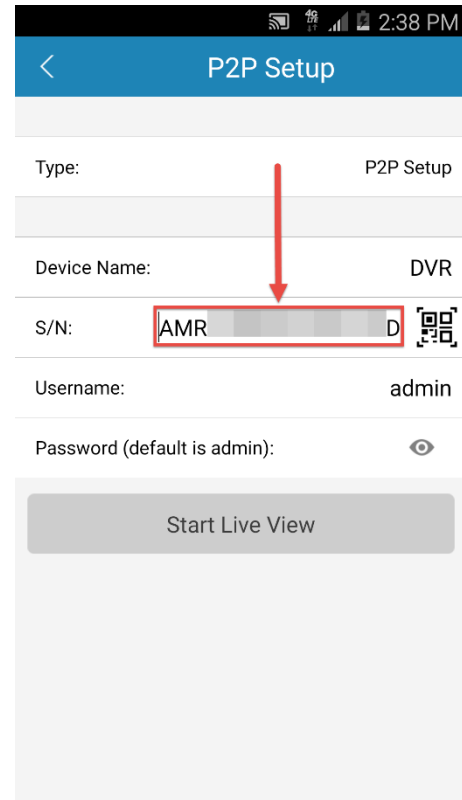

#### Entering serial number manually (technical method - harder):

In order to locate your serial number, you must either have physical access to the DVR or computer access to the web interface.

On the bottom of the DVR console, there is a sticker with the serial number printed on it. It will begin with 'AMR'. Write this down.



Then enter this into the S/N field of the P2P Setup screen of your app.

Otherwise, if you are setting up the app after gaining local access with a computer, log into the web interface with your username and password. Then, click the 'i' icon at the top of the screen:



Make sure you are on the 'VERSION' tab, and you will see the serial number written there:

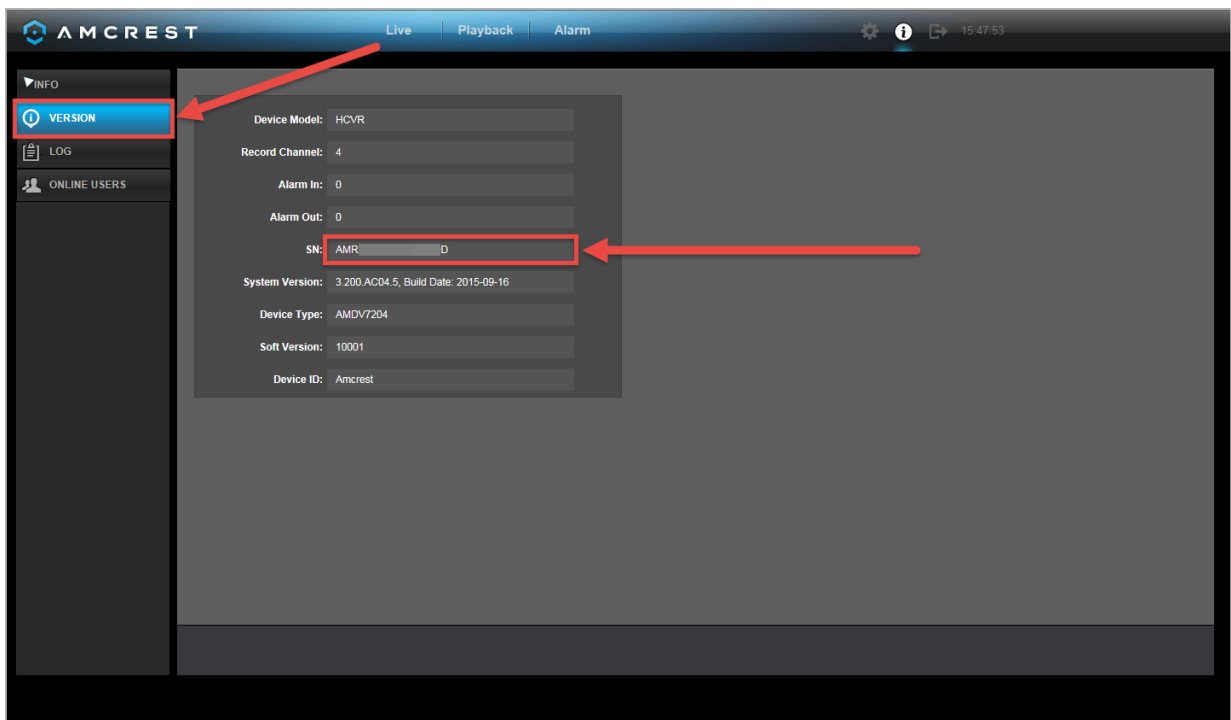

Write it down, then enter it into the S/N field of the P2P Setup Screen of your app.

- Return to your app's **P2P Setup** page, and enter your **username** and **password**. These are the same credentials used to access the console's built-in interface directly. Refer to part 3 of this guide: **Console Setup > Logging in**.

If you skipped that step, or this is your first time accessing the DVR, the default username "admin" and password "admin" will work and you will be prompted to change your password.

After entering your **Username** and **Password**, tap **Start Live View** to connect to your DVR.

There will be one instructional screen that appears, you can swipe this out of the way before beginning to view the live streams from your connected cameras.

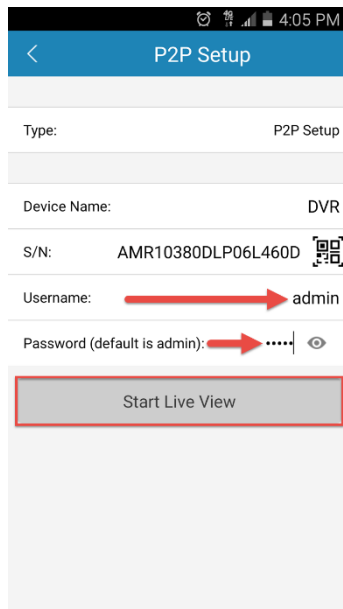

**App setup not working? (troubleshooting steps)**

1. **Re-enter login credentials:** Are you getting a (quote 'incorrect password' error) message? Try double checking your username and password. These will be the same credentials used to log into the DVR console's built-in interface.
2. **Confirm your phone is online:** Make sure that your phone is receiving a strong WiFi or cellular data signal. Confirm the Internet connection is working by loading a webpage or testing another internet enabled app.
3. **Confirm the DVR is online:** Make sure an Ethernet cable is connected from your router to the Internet port on the back panel of your DVR console. (For help with this, refer to part 2 of this guide: **Hardware Setup > Setting up the cable connectons.**)
4. **Confirm P2P is enabled:** In order to use the P2P Setup to gain plug-and-play instant access, P2P needs to be enabled on the DVR. It will be enabled by default. To confirm P2P is enabled, log into the main console built-in interface for your DVR and select Network from the Main Menu (in the Settings row). Then, click P2P from the left navigation panel (on the bottom). Make sure the checkbox is checked next to "Enabled". If it is not, check it, click Apply down below, then attempt the P2P App Setup again (tap Start Live Preview).
5. **Confirm the serial number:** if you entered the serial number manually, double check that it is correct and re-enter it. This does not apply if you used the QR code scan.
6. **Still not working?**  
If you have tried all of the above troubleshooting steps, try rebooting your DVR. Then, restart your phone and try the P2P Setup on your app again. Contact support if you are still unable to gain access.

To view a video on how to setup the Amcrest DVR for remote access on a smartphone or tablet, go to <http://amcrest.com/videos> and view the video titled "How to Setup Amcrest HDCVI DVR for Remote Access on Smartphone/Tablet".



## Amcrest View Pro interface overview

Once the app is setup to work with your DVR, it should look like the image below on the left. Here, you will be able to access all crucial functions like taking snapshots, manual recordings, etc.

Clicking the Menu Icon on the top left hand corner will open the menu for this app, and it should look like the image below on the right.

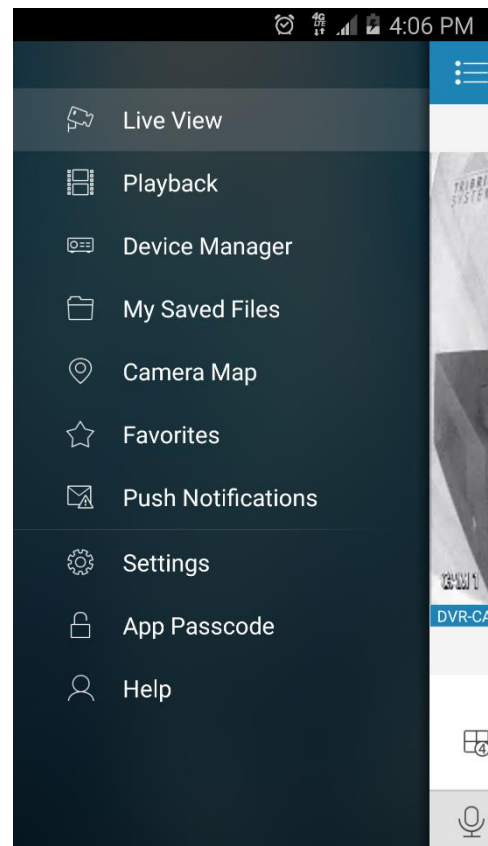
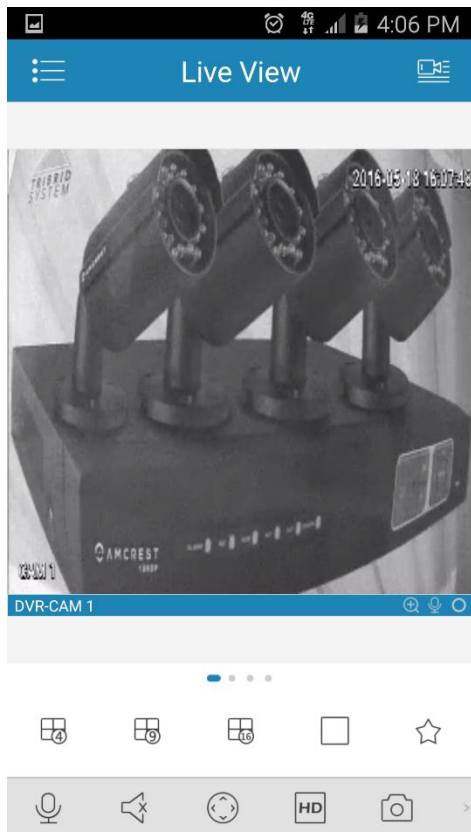

Live Preview is the default screen that the app opens on, but from the menu, **Playback**, and **Device Manager** can be opened, as well as other menu items for other features.

**Note:** For help identifying and understanding app features, either tap the icon to see a tooltip description, or open the main menu, then tap **Help** to learn more.

## 7. Amcrest View Web Portal Setup

You can access your DVR through a computer using the P2P web portal **AmcrestView.com** for quick plug-and-play access. It uses the same technology as the Amcrest View mobile app and is an easy, non-technical setup method.

There are 2 methods of accessing your DVR using AmcrestView.com: the **user method** (registering an account for login), and the **device method** (instant direct access using the serial number).

Both of these methods require that the Amcrest **browser plugin** be installed for AmcrestView.com.

### Installing the AmcrestView.com browser plugin

1. Open Internet Explorer, type "[www.amcrestview.com](http://www.amcrestview.com)" into the search bar, and hit Enter. This will take you to the login screen:

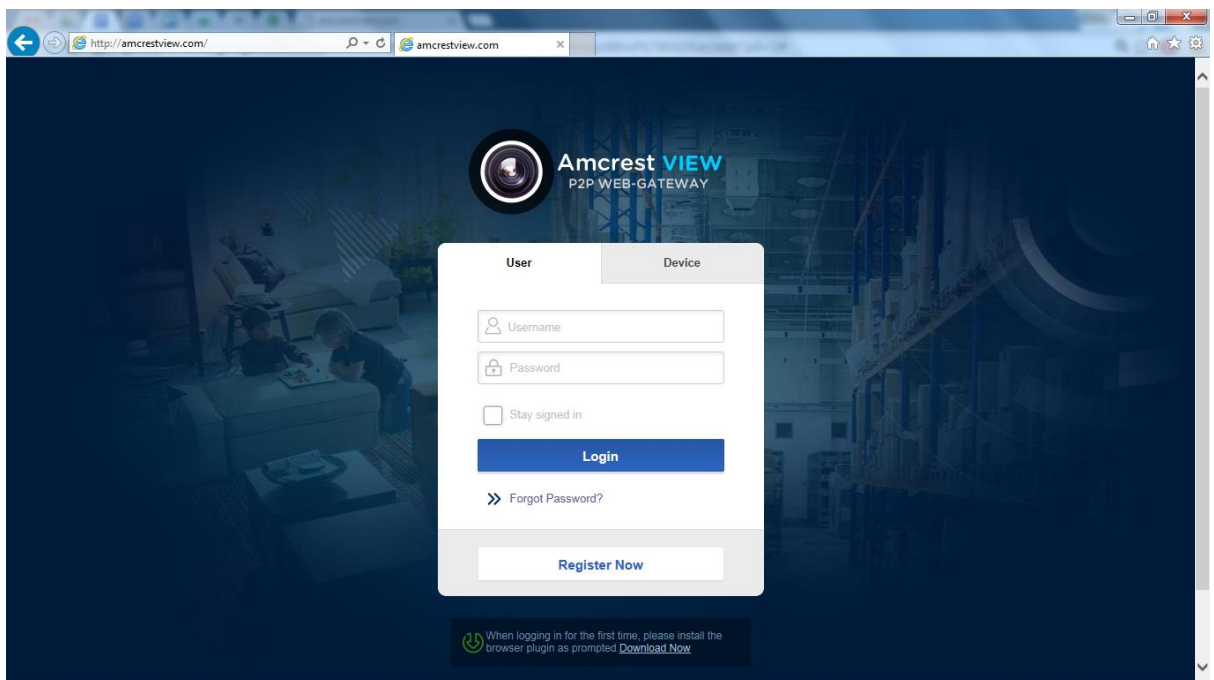

2. Once you're on the login page, you will see a message about installing the plugin below the login box. Click **Download Now**:

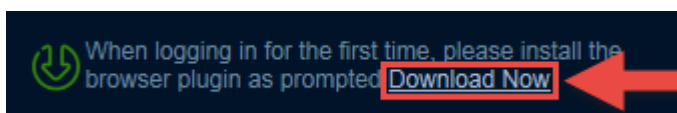



- This will take you to another page where you will need to click the **Download Now** button:

Setup **Web Client** Plugin  
In order to use AmcrestView.com, you must first install/update the ActiveX plugin.

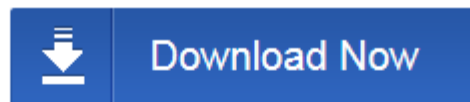

Please restart the browser after upgrade.

- You will be prompted by the browser to install the plugin. Click **Run**:



- You may be prompted to verify this download. This software is not harmful to your computer and will not make any unwanted changes. To verify, start by clicking **View Downloads**:

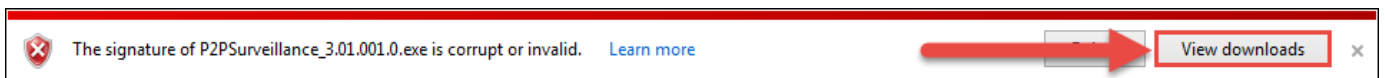

- In the View Downloads page, right click the plugin, then click **Run Anyway**.

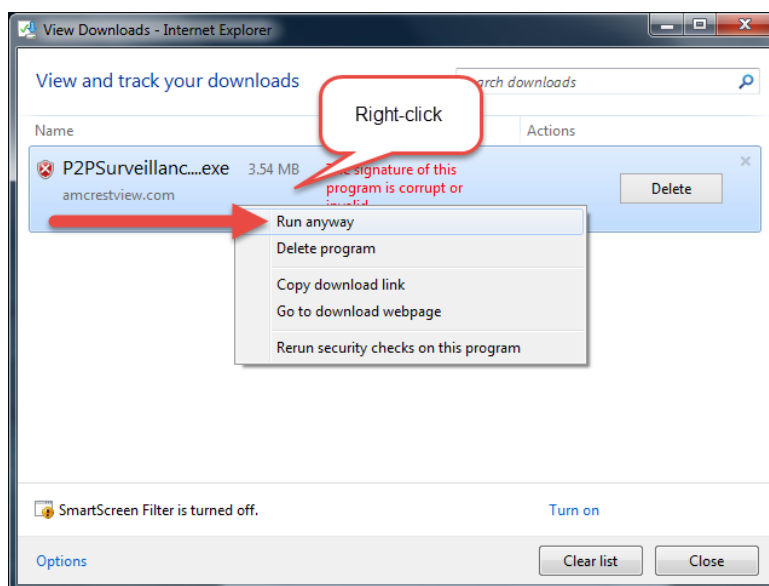

- 7. The plugin will close your browser sessions to install. Save any pages, then click **Yes**:

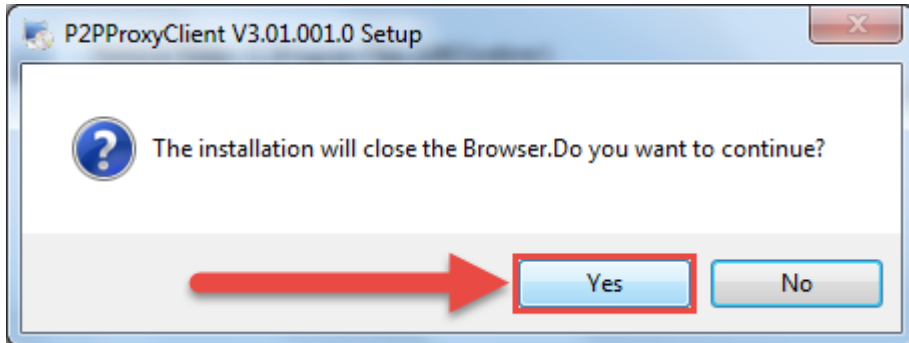

- 8. On the next prompt, it will say the install was successful and ask you to restart your browser. Click **OK**:

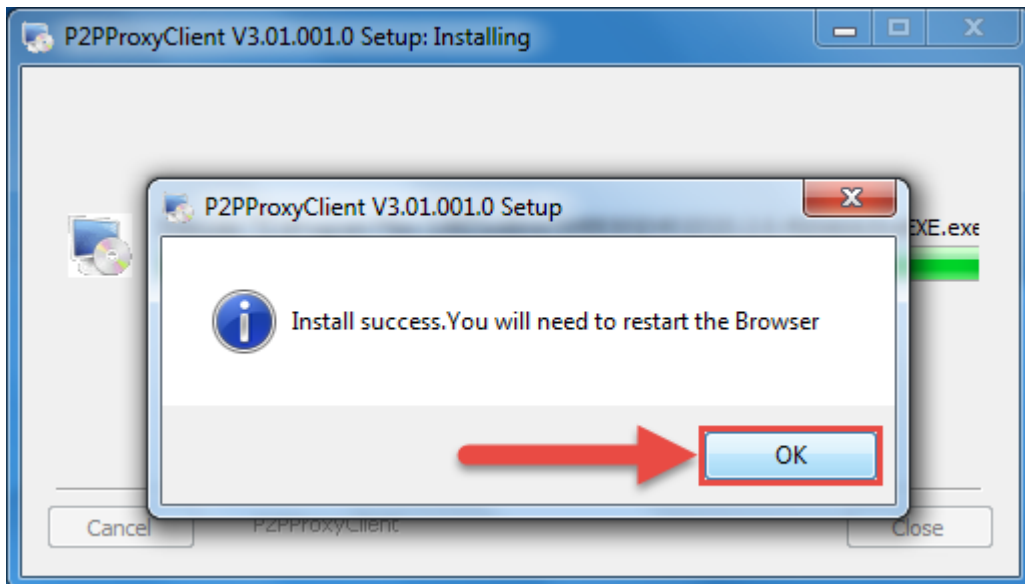

- 9. You will be taken back to the login page and see another notification from your browser asking you to allow this plugin on this web page. Click the small arrow next to **Allow**, then click **Allow for all websites**:

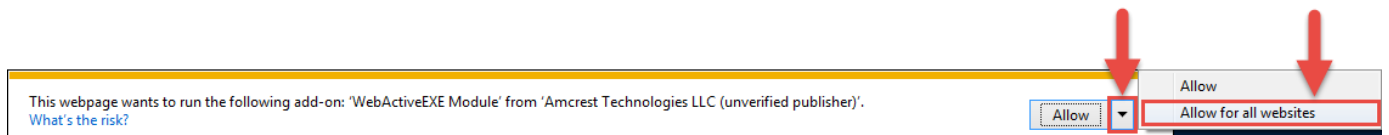

- Another popup will appear asking you to allow this plugin. Mark the checkbox next to **Do not show me the warning for this program again**, then click **Allow**:

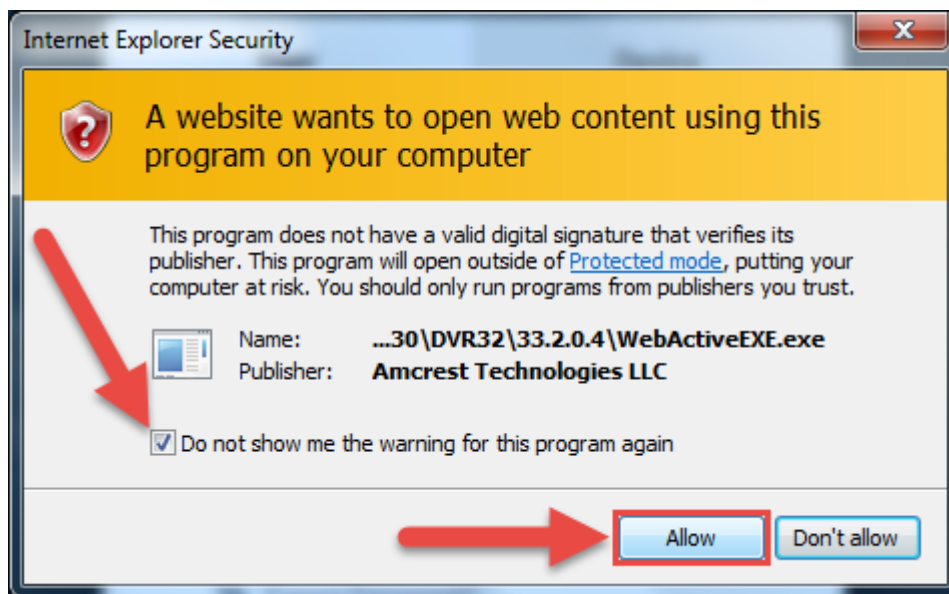

Now the plugin has been installed successfully and you can continue on to register for an account for DVR access through AmcrestView.com

## User method

The **user method** requires that you first install the Amcrest browser plugin for AmcrestView.com. Then, you can register for an account to set up your DVR.

- On the main login screen, [www.amcrestview.com](http://www.amcrestview.com), click the **Register Now** button:

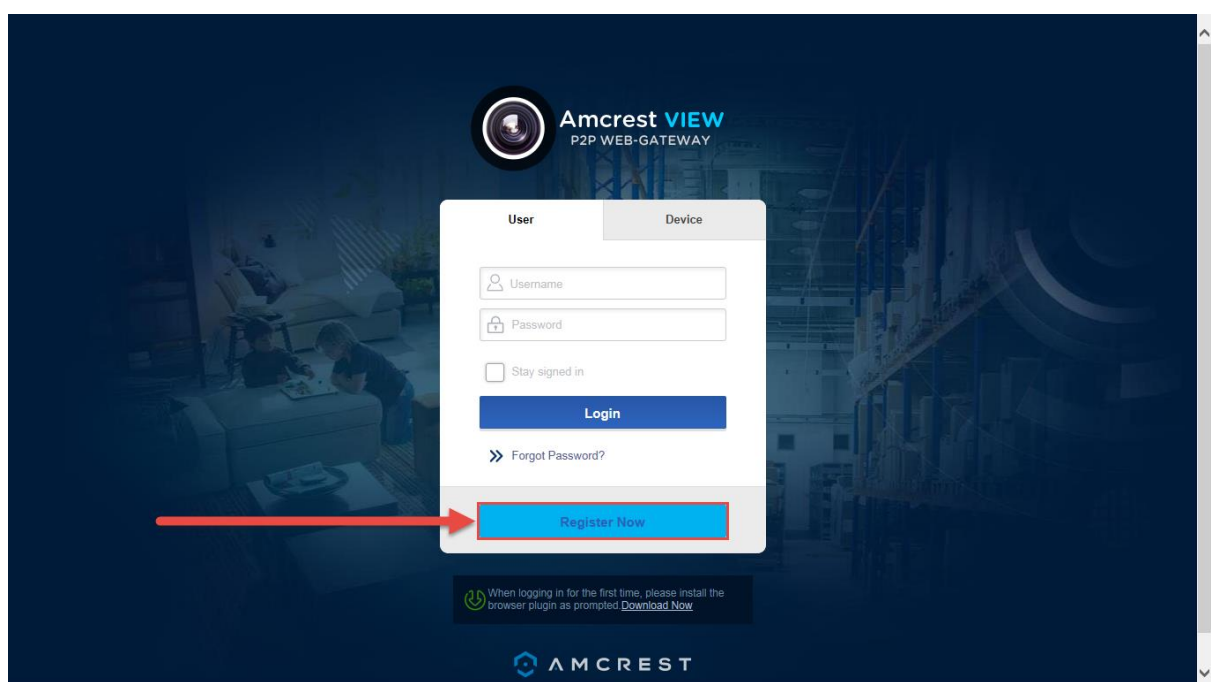

- You will be taken to the registration form. Enter your **Username**, **Password**, then **Confirm Password**, type your **Email**, enter the **Verification Code**, make sure the box is checked confirming you've read the 'Amcrest Terms of Service', then click **Create an Account**:

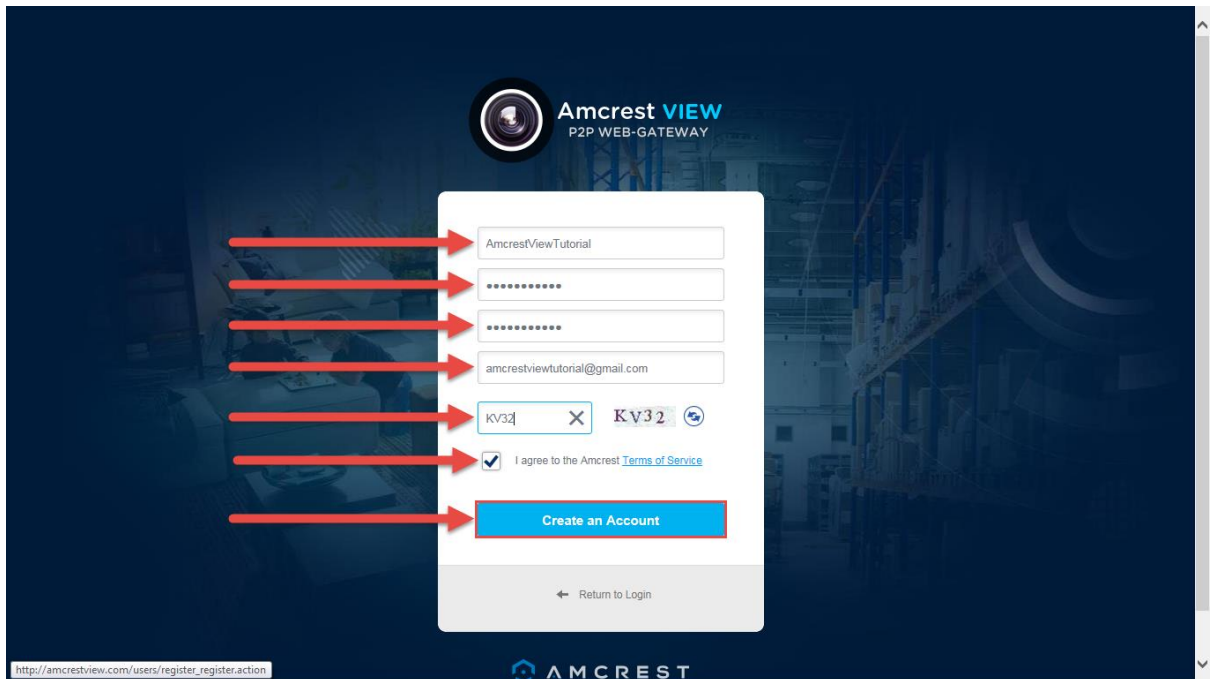

Amcrest **VIEW**  
P2P WEB-GATEWAY

AmcrestViewTutorial

.....

.....

amcrestviewtutorial@gmail.com

KV32 X KV32

I agree to the Amcrest [Terms of Service](#)

**Create an Account**

[← Return to Login](#)

[http://amcrestview.com/users/register\\_register.action](http://amcrestview.com/users/register_register.action)

AMCREST

- You will see the **Registration Successful** message and a confirmation email will be sent to you:

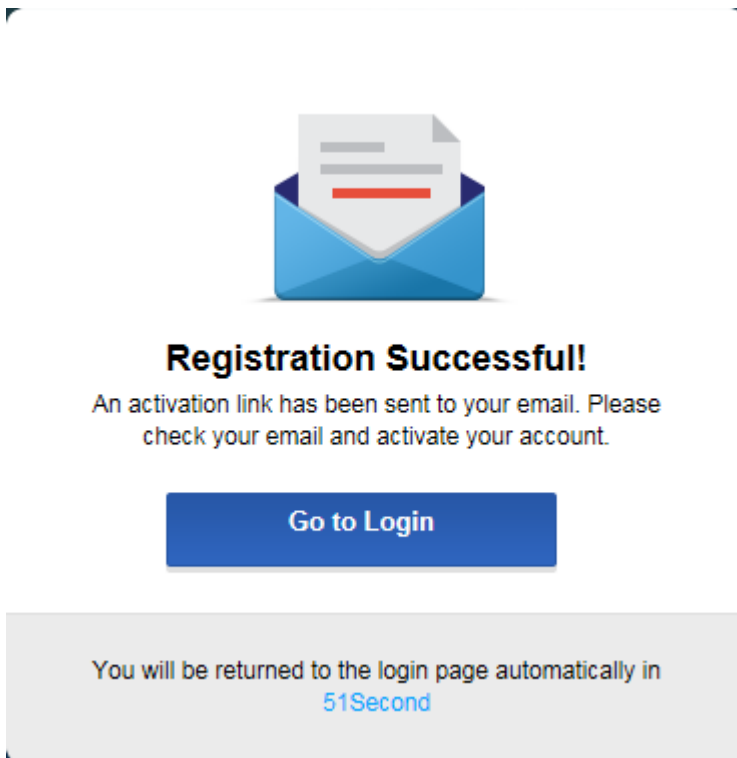

Check your email, and click the confirmation email from AmcrestView.com:

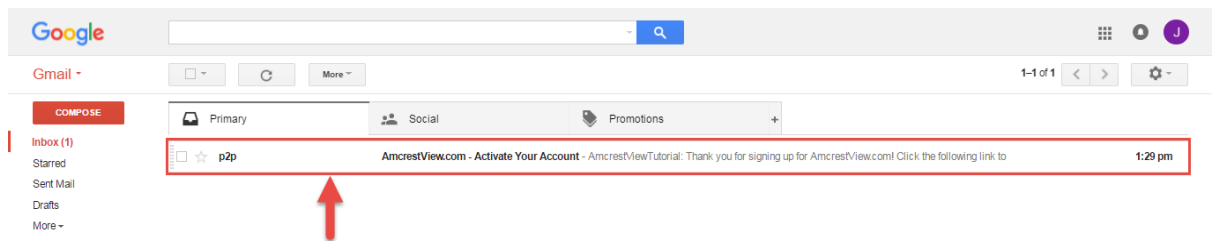

4. Once you've opened the email, click the confirmation link inside to complete your registration:

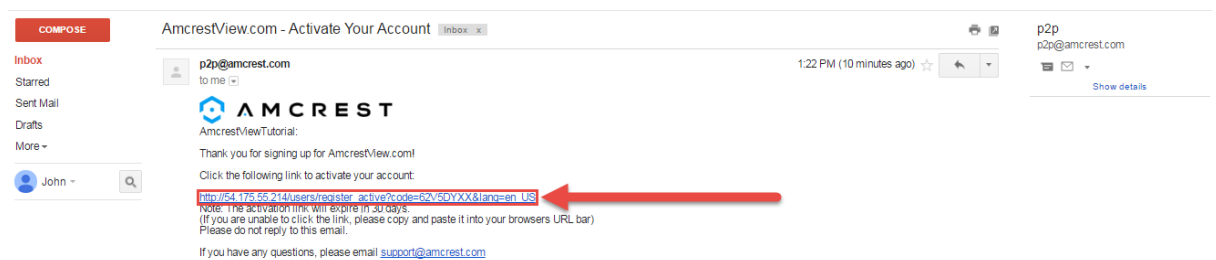

5. You will be taken back to AmcrestView.com and shown confirmation that your account has been activated. Click **Go to Login**:

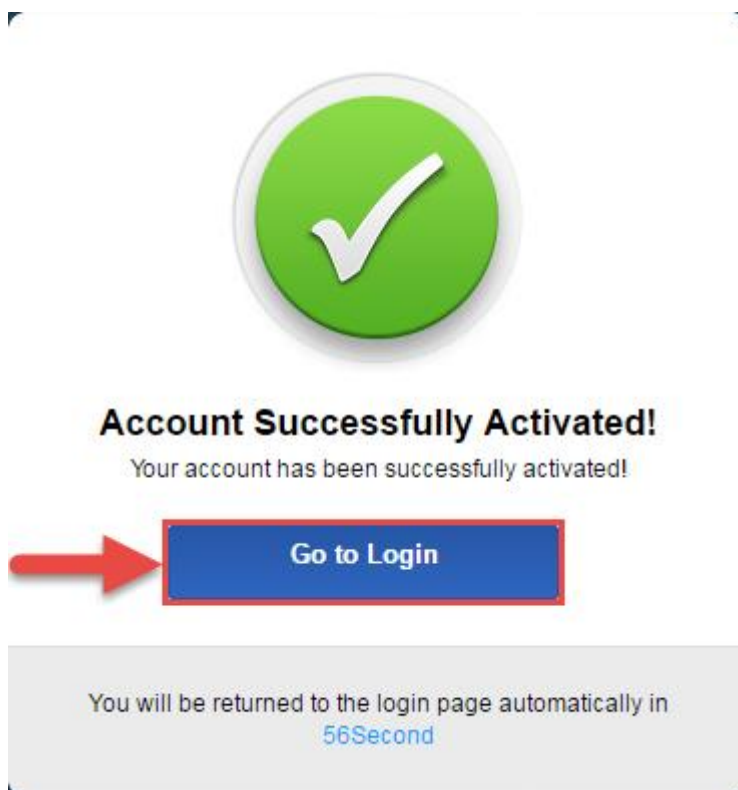

- You will be taken back to the login screen. Enter your new AmcrestView.com username and password, then click **Login**:

User Device

AmcrestViewTutorial

Stay signed in

Login

>> Forgot Password?

Register Now

- A popup will appear from your Windows Firewall. Click **Allow access**:

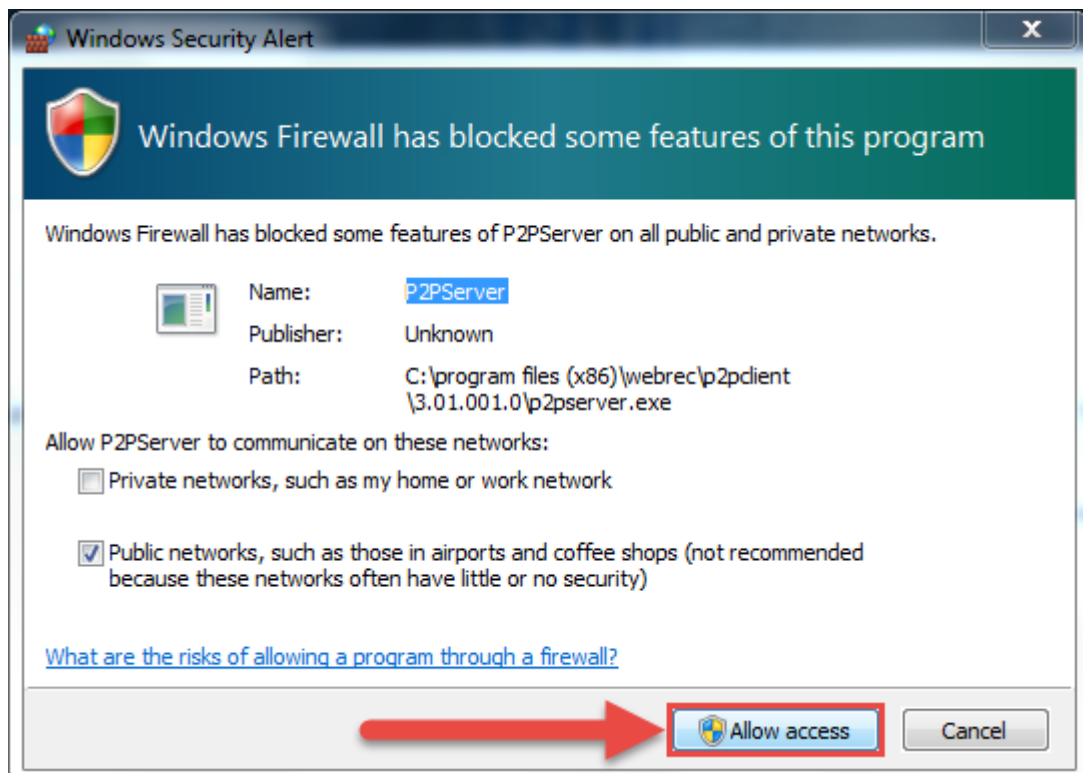

- You will be taken to the main screen of your account. From here, click the **Add Device** button:

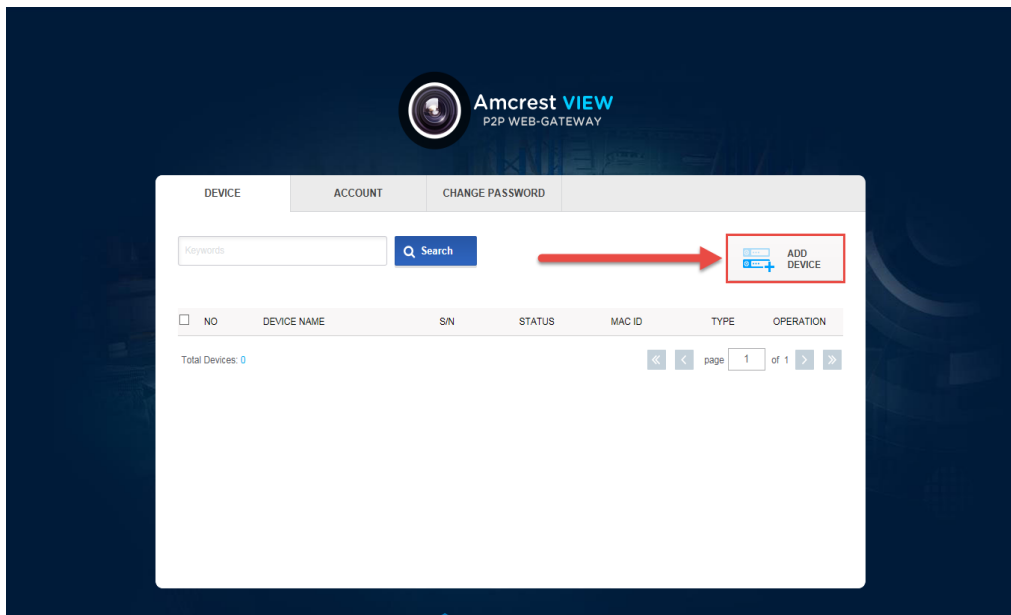

- Now you can enter your DVR's information. Enter a **Device Name** (this can be anything). Then, fill in the **S/N** (serial number) this can be found on the sticker attached to the bottom of your DVR or through the web interface. Please refer to part 6 of this guide: **Amcrest View App Setup > Entering serial number manually(technical method - harder)**.

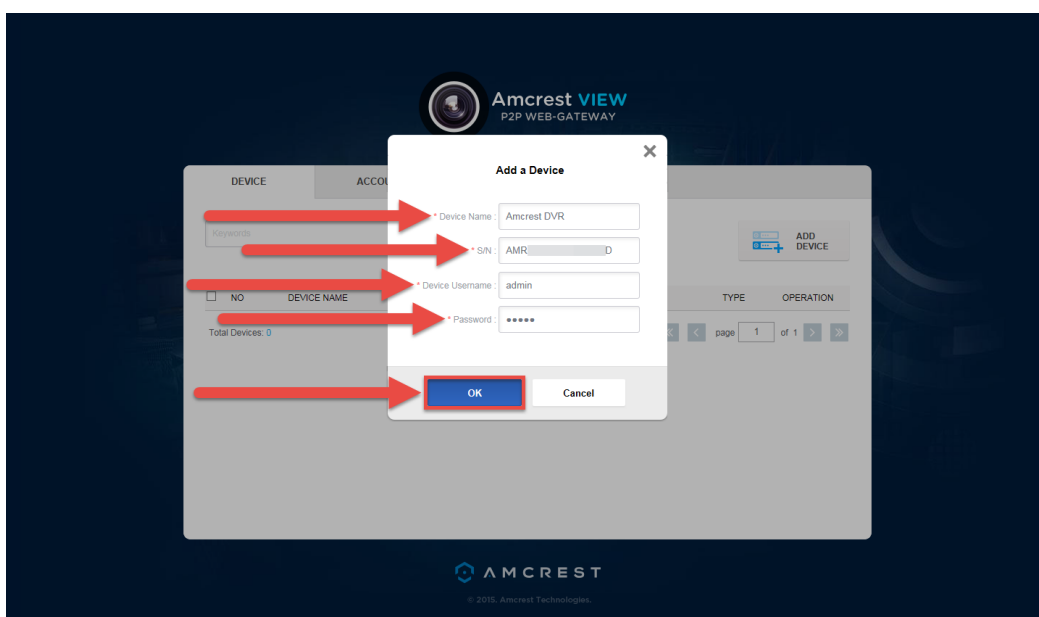

Enter your username and password for the DVR, not the username and password you just created for AmcrestView.com. To find your DVR login credentials, please refer to part 4 of this guide: **Console Setup (Login & Startup Wizard) > Logging in**. Finally, click **OK**:

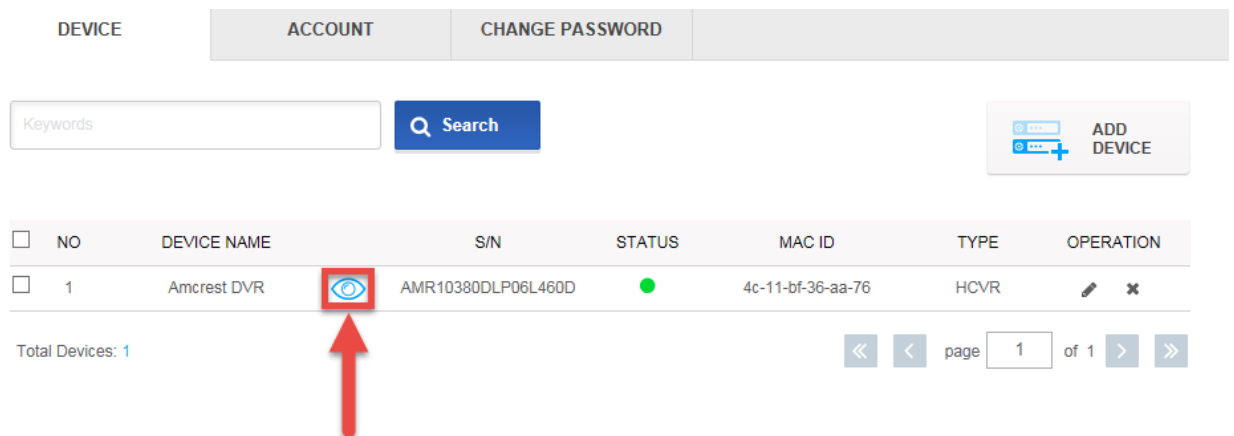

10. You will then see your DVR added to the device list on the main screen. Click the 'eye' icon to view the live feed:



The screenshot shows the Amcrest View Web Portal interface. At the top, there are tabs for 'DEVICE', 'ACCOUNT', and 'CHANGE PASSWORD'. Below these is a search bar with a 'Search' button and an 'ADD DEVICE' button. A table lists the devices:

<input type="checkbox"/>	NO	DEVICE NAME	S/N	STATUS	MAC ID	TYPE	OPERATION
<input type="checkbox"/>	1	Amcrest DVR	AMR10380DLP06L460D	●	4c-11-bf-36-aa-76	HCVR	  

Below the table, it says 'Total Devices: 1' and 'page 1 of 1'. A red arrow points to the eye icon in the 'OPERATION' column of the first row.

11. Your browser will give you a notification asking you to allow popups from AmcrestView.com. Click **Options for this site**, then click **Always allow**:



The screenshot shows a browser notification bar with the text 'Internet Explorer blocked a pop-up from \*.amcrestview.com.'. There are three buttons: 'Allow once', 'Options for this site', and 'More settings'. A red box highlights the 'Options for this site' button, and a red arrow points to the 'Always allow' button in the expanded menu.

12. You will be taken to the live view page and given a notification to allow the plugin to pull the video feed through here. Click the small arrow to the right of **Allow**, then click **Allow for all websites**:

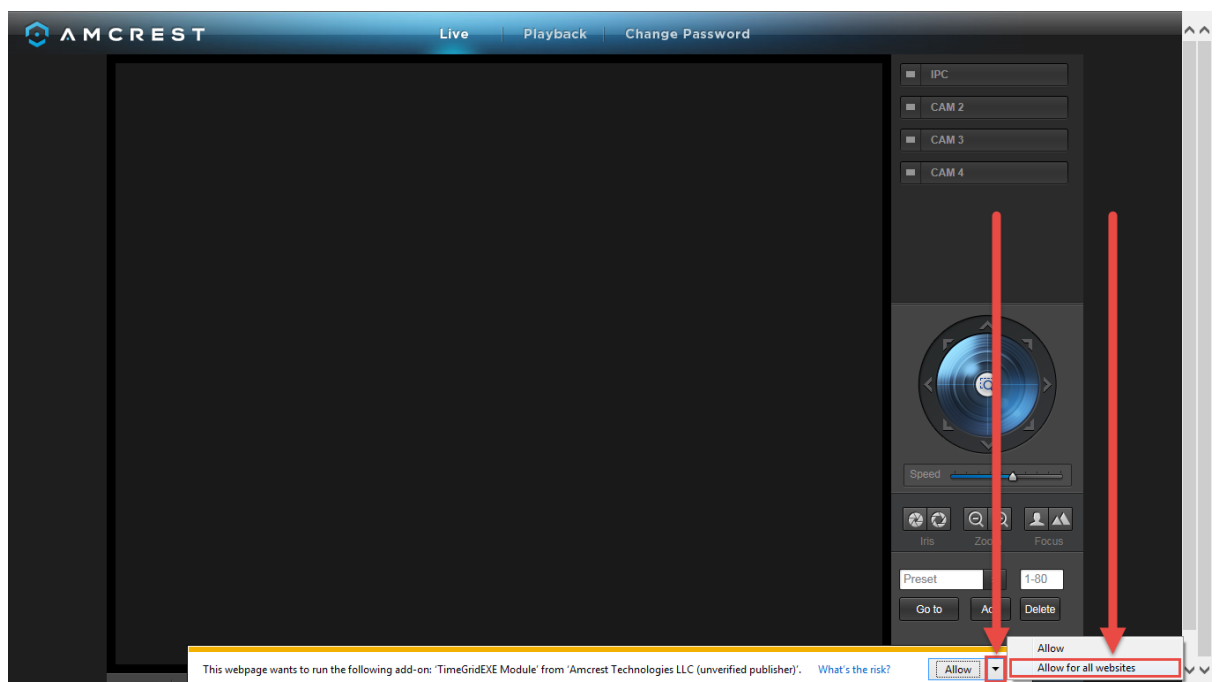

The screenshot shows the Amcrest live view page. At the top, there are tabs for 'Live', 'Playback', and 'Change Password'. The main area is a large black rectangle representing the video feed. On the right side, there are controls for IPC, CAM 2, CAM 3, and CAM 4. Below these are controls for Speed, Iris, Zoom, and Focus. At the bottom, there is a notification bar with the text 'This webpage wants to run the following add-on: TimeGridEXE Module' from 'Amcrest Technologies LLC (unverified publisher)'. There are two buttons: 'Allow' and 'Allow for all websites'. A red box highlights the 'Allow' button, and a red arrow points to the 'Allow for all websites' button.



13. A final popup will appear asking you to confirm that you allow this plugin on your browser. Mark the checkbox next to **Do not show me the warning for this program again**, then click **Allow**:

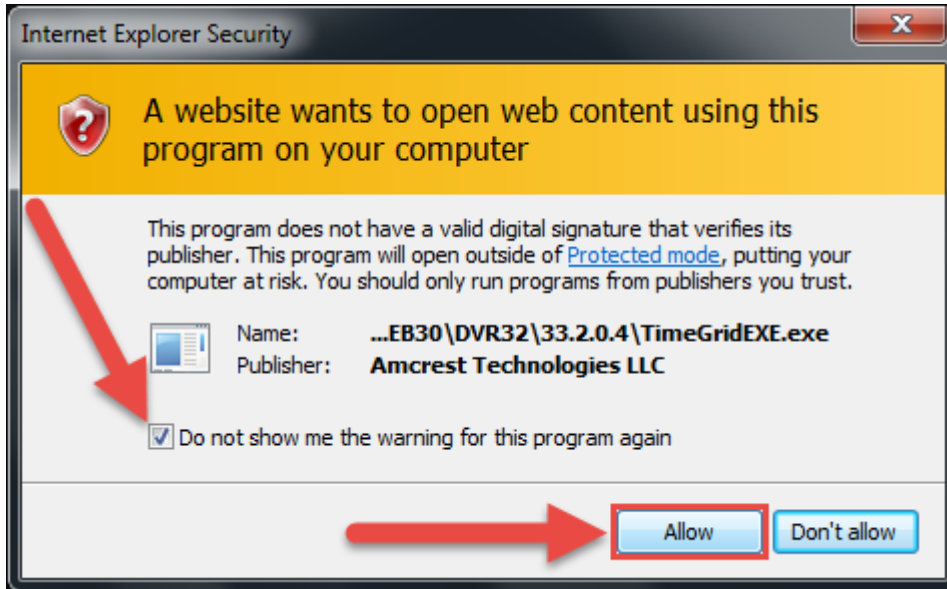

14. Now you can enable any of your added cameras to see their live feeds. In the top-right panel, there is a channel list. Click the small square icon to enable your feed for an added camera to see the video feed:



Click the "S" to change it to an "M" which stands for "Main Stream" and will give you a full HD quality video stream. To go back to "Sub Stream", for lower quality video (that works better on slower internet connections), click the "M" and change it to an "S" again.

## Device method

To login to your DVR quickly, without having to register, you can use the **device method**. This method still requires that you install a plugin, which is covered above, but can be done with only the DVR's login credentials and the **serial number**.

1. On the main login screen for AmcrestView.com, click the **Device** tab:

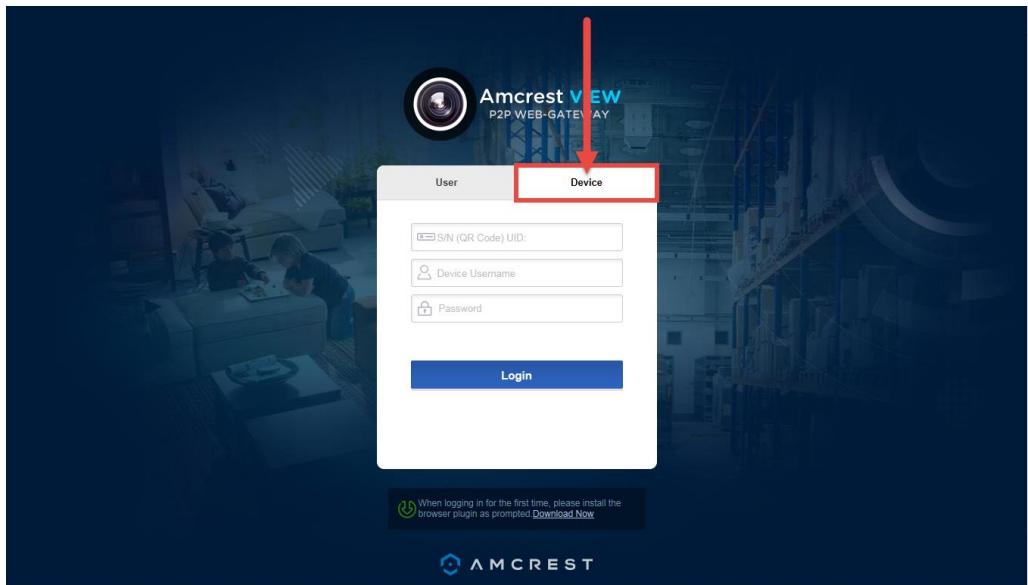

2. Enter your DVR's **S/N**(serial number) into the top field, enter your DVR's username and password, then click **Login**.

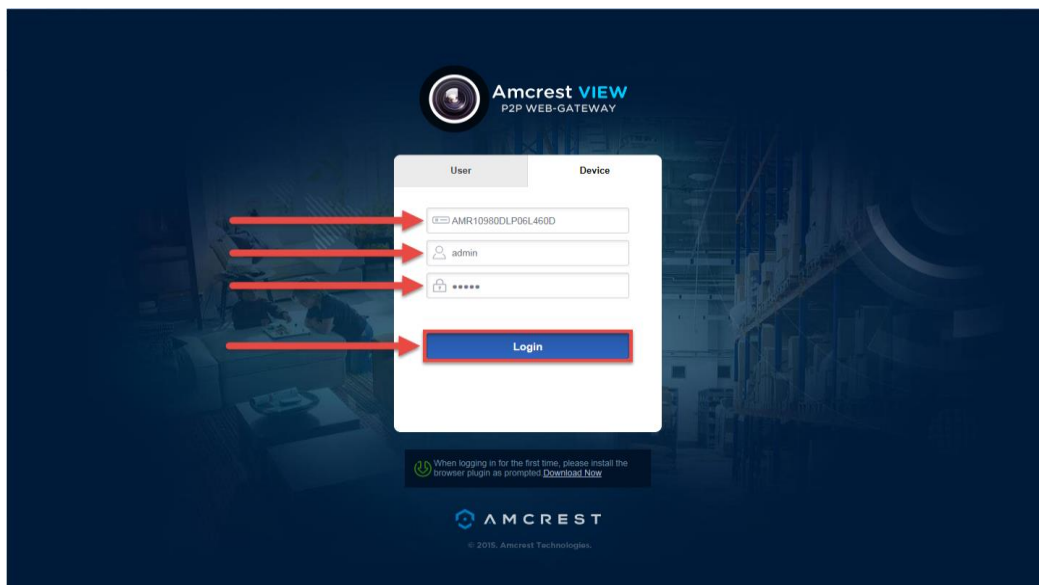

To find your DVR's login credentials, please refer to part 4 of this guide: **Console Setup (Login & Startup Wizard) > Logging in**.

- This will take you straight to the live view screen. You will see a notification from your browser asking you to allow the plugin. Click the small arrow to the right of **Allow**, then click **Allow for all websites**:

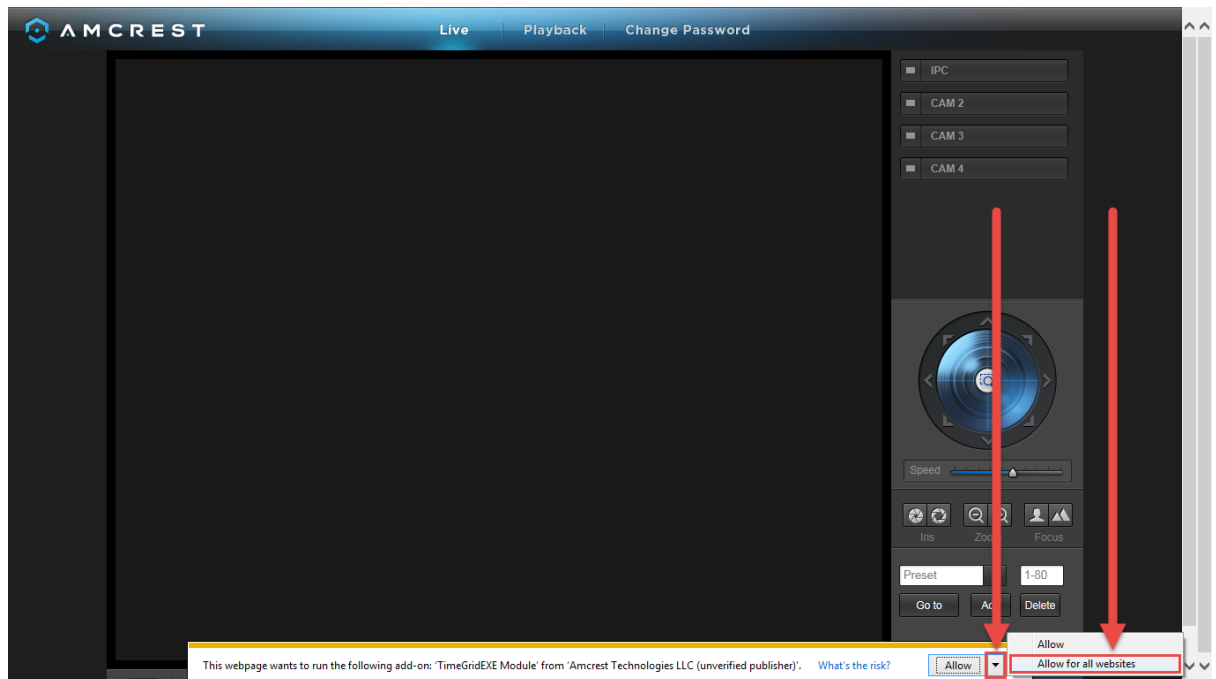

- You will see a popup asking you to confirm that you allow this plugin. Check the box next to **Do not show me the warning for the program again**, then click **Allow**:

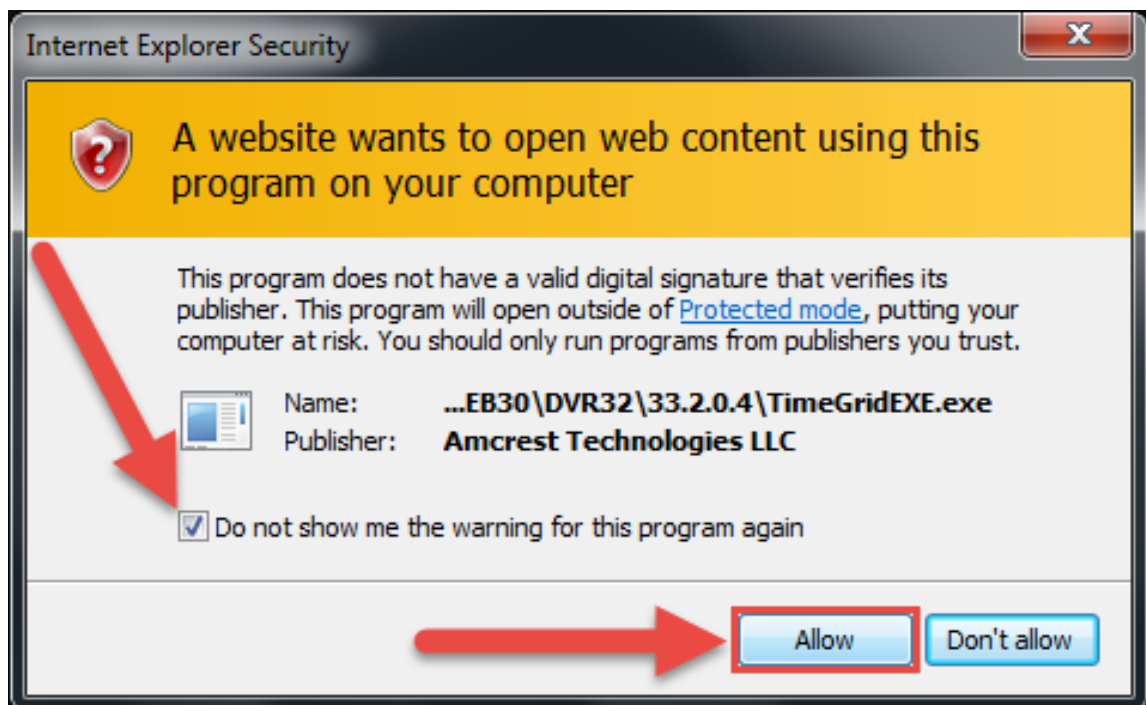

- Now you can enable any of your added cameras to see their live feeds. In the top-right panel, there is a channel list. Click the small square icon to enable your feed for an added camera to see the video feed:



Click the “S” to change it to an “M” which stands for “Main Stream” and will give you a full HD quality video stream. To go back to “Sub Stream”, for lower quality video (that works better on slower internet connections), click the “M” and change it to an “S” again.

## AmcrestView Web Interface Overview

There are two main sections inside of the AmcrestView web interface: the main **device list section** (for anyone logged in with a registered account) and the **live view section** (can be accessed by both registered users and those accessing their DVRs using the **device method** covered above).

### Device list section

The device list section has 3 main tabs. The first is the **DEVICE** tab:

NO	DEVICE NAME	S/N	STATUS	MAC ID	TYPE	OPERATION
1	Amcrest DVR	AMR10380DLP06L460D	<span style="color: green;">●</span>	4c-11-bf-36-aa-76	HCVR	

This page shows you a list of any added devices and is where you can click the 'eye' icon to view your DVR's live camera feeds. This is where you can **ADD DEVICE**, **Search**, edit, or delete your added devices.

The next tab is the **ACCOUNT** tab:

This is where you can see your **Username**, change your **Country**, see your **Email**, and enable email notifications from AmcrestView.com.

The last tab for the device list section is the **CHANGE PASSWORD** tab:

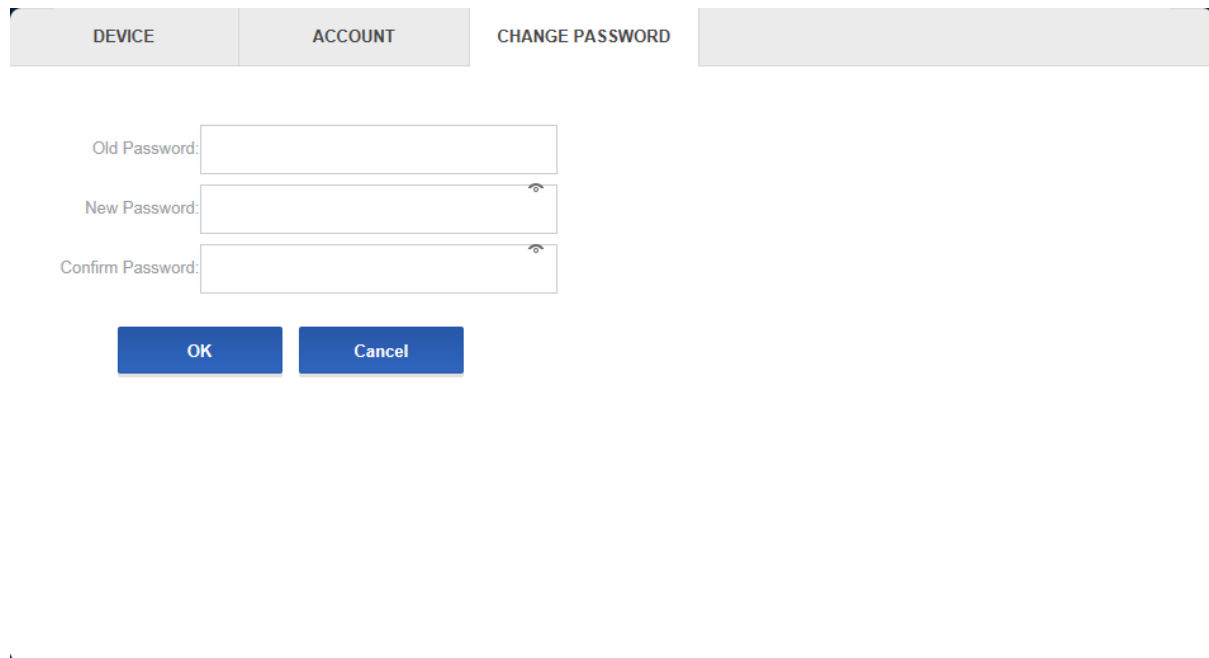

DEVICE ACCOUNT CHANGE PASSWORD

Old Password:

New Password:

Confirm Password:

OK Cancel

Here, you can change your password.

### Live view section

The live view section is where you can see the live camera feeds and playback footage for any cameras added to your DVR. The first tab is the **Live** tab:



Here, you can enable the live feeds for any connected cameras, control PTZ, take snapshots, use 2-way audio, view them in full screen, and more.

The next tab is the **Playback** tab:

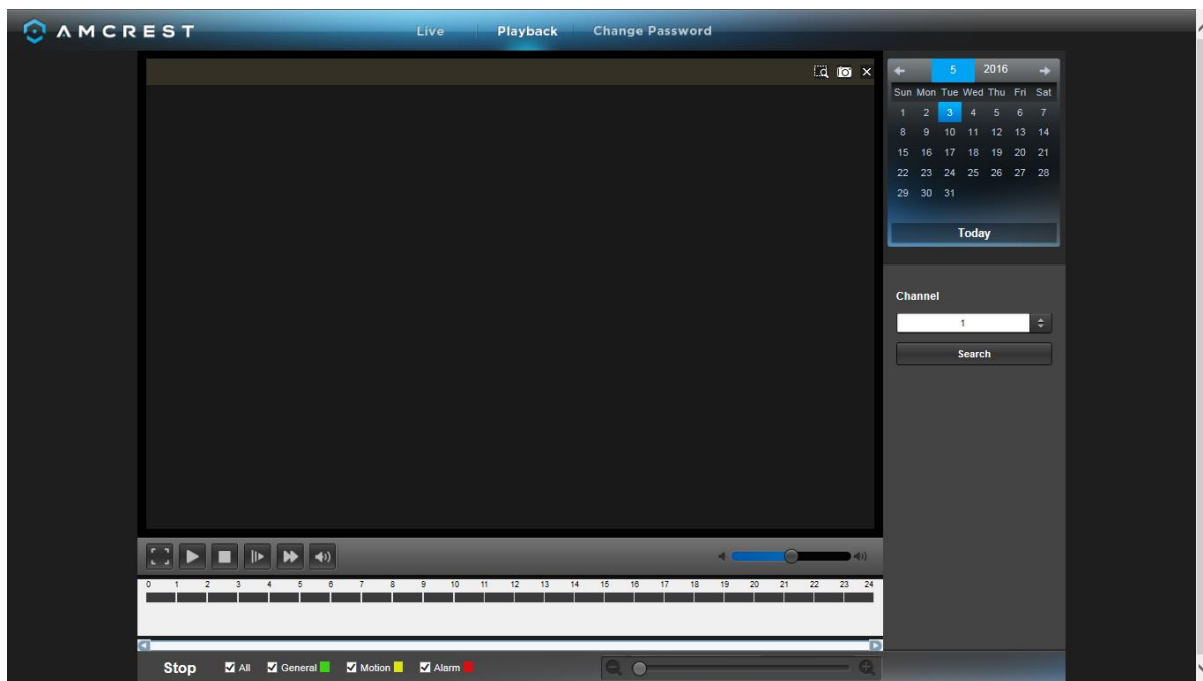

Here, on the right panel, there is a calendar for you to choose which day you'd like to see footage from, and you can choose a channel to select which camera you want to see footage from. The timeline on the bottom allows you to play, stop, forward, etc.

**Note:** Keep in mind that you can see the live feeds from your cameras whether or not a hard drive is installed in your DVR. However, you will need to have a hard drive installed and recordings properly configured in order to view the playback.

## 8. References & Contact Information

For a detailed operational introduction, please refer to our CD included in your package for the electronic version of the *User Manual*.

To view setup videos for many of the steps outlined in this guide, go to <http://amcrest.com/videos>

This quick start guide is for reference only. Slight differences may be found in the user interface.

All the designs and software here are subject to change without prior written notice.

All trademarks and registered trademarks mentioned are the properties of their respective owners.

If you have any questions or concerns, please contact us at [support@amcrest.com](mailto:support@amcrest.com), or call us at 888-212-7538.